

MasoneilanTM Power Industry Control Solutions



Masoneilan

a Baker Hughes business

Table of Contents

Innovation by Design	3
Typical Fossil Fuel Power Plant System	4-5
Typical Combined-Cycle Power Plant System	6-7
Fossil Fuel Power Plant Typical Applications	8-9
Combined-Cycle Power Plant Typical Applications	10-11
21000 Series Top-Guided Globe/Angle Valve	12
21000 Series Options	13
41005 Series Cage-Guided Globe/Angle Valve	14
41005 Series Options	15
80000 Series 3-Way Diverting or Combining Valve	16
35002 Series Camflex II Eccentric Plug	18
36005 Series V-Max Control Ball	19
39003 Series High-Performance Butterfly Valve	19
48000 Series Cage-Guided Control Valve	20
49000 Series Globe and Angle Style with Lo-dB or V-Log Trim	20
78400/18400 Series LincolnLog	21
79003 Series Angle Valve with VRT Trim	21
84003 Series SteamForm	21
SVI II AP – Advanced Performance Digital Positioner	22
SVI FF Advanced Foundation® Fieldbus Positioner	22
12400 Series Digital Level Transmitter/Controller	23
ValVue 3 Software	23

Valve Solutions and Services for the Energy Industry

Baker Hughes provides the most complete control valve portfolio for the power industry with its wide range of engineered products and general service control valves. Baker Hughes valve technology, digital instrumentation, and advanced diagnostics will improve plant efficiency and reduce costly unplanned down time.

Innovation by Design

Baker Hughes Masoneilan Products created and patented the automatic governor for controlling steam pumps in 1883. Over the last 130 years, the brand has pioneered numerous industry firsts in technology and standards for the control valve industry including the standard measure of valve capacity, *Lo-dB™* trim, and unique engineered technology for the entire energy industry. Baker Hughes is here to provide the most effective technology and the complete solution for your plant.



Typical Fossil Fuel Power Plant System

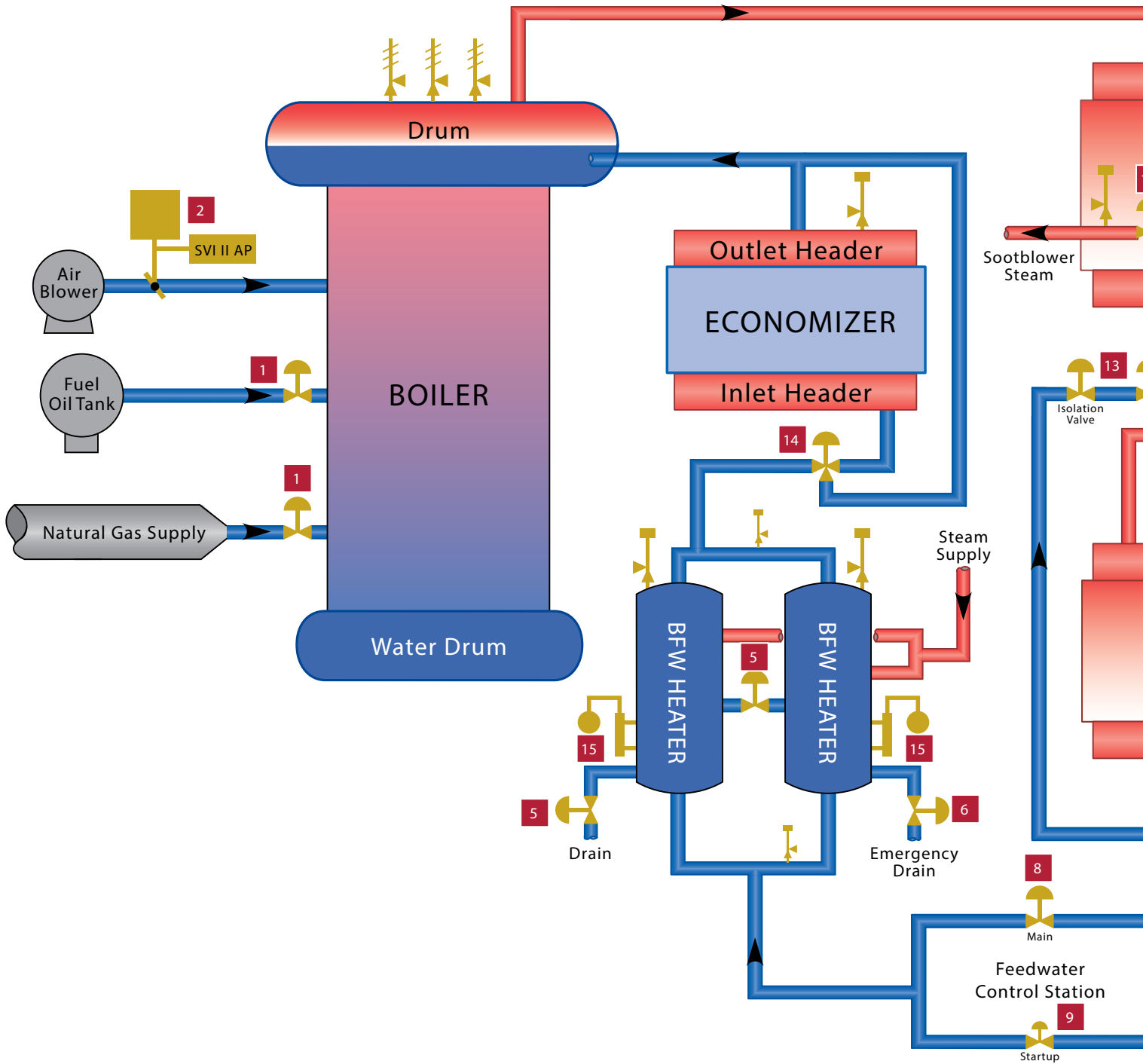

 Masoneilan Control Valve

 Masoneilan Level Device

 Sa

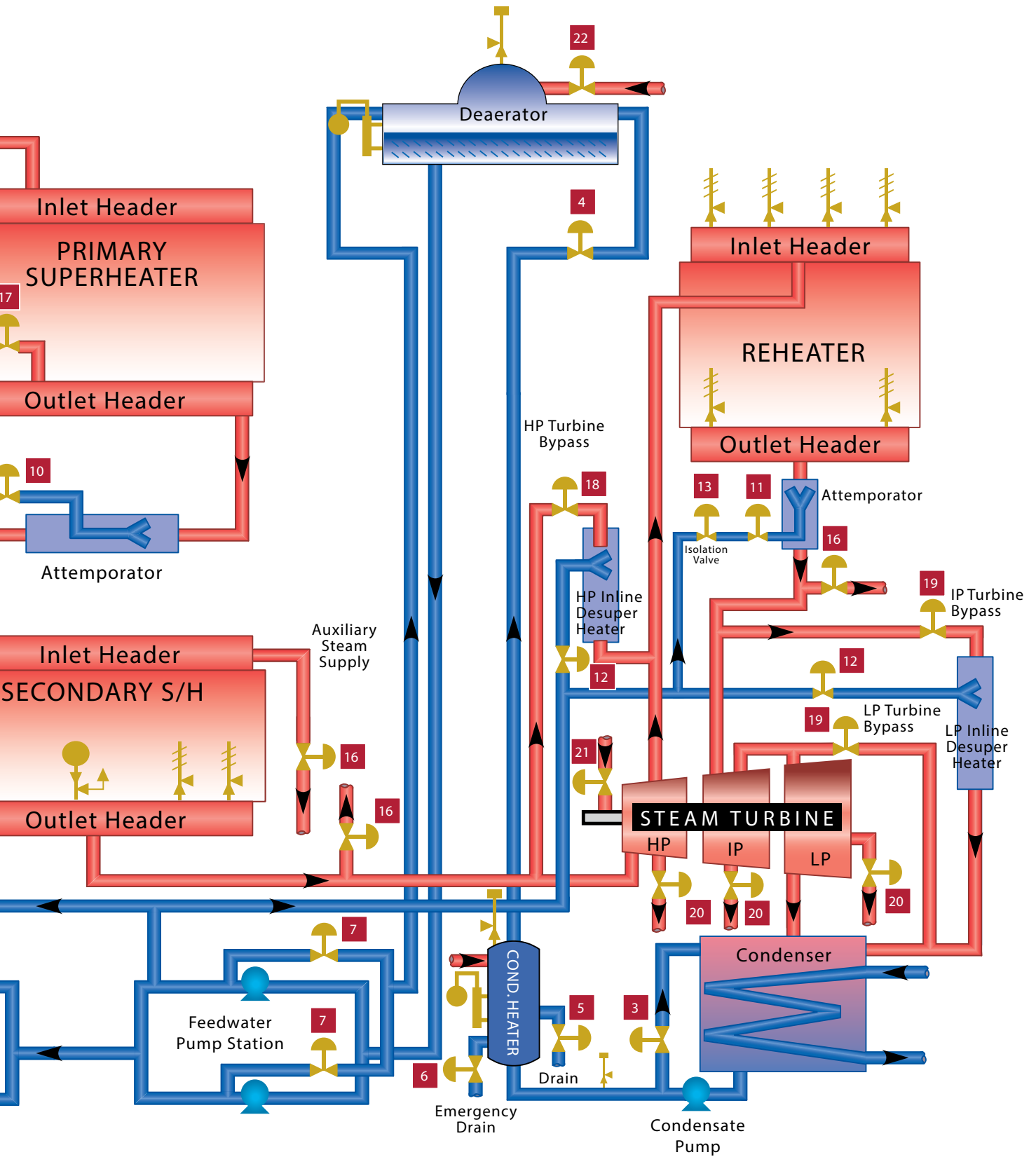

Safety Valve



Safety Relief Valve
(Option - Pilot Operated Relief Valve)



Electromatic Ball Valve

Typical Combined-Cycle Power Plant System

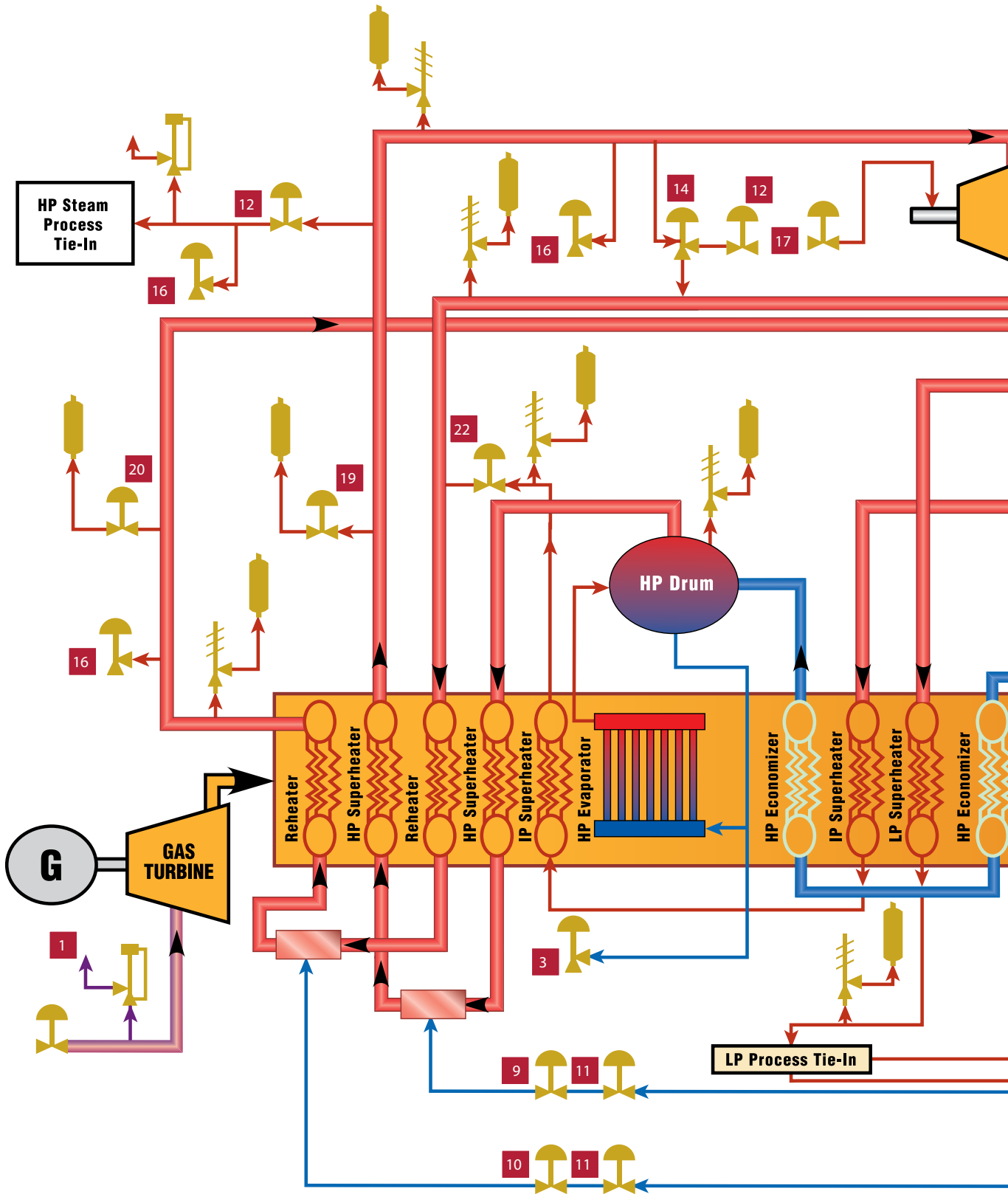

 **Masoneilan Control Valve**

 **Masoneilan Steam Conditioning Valve**

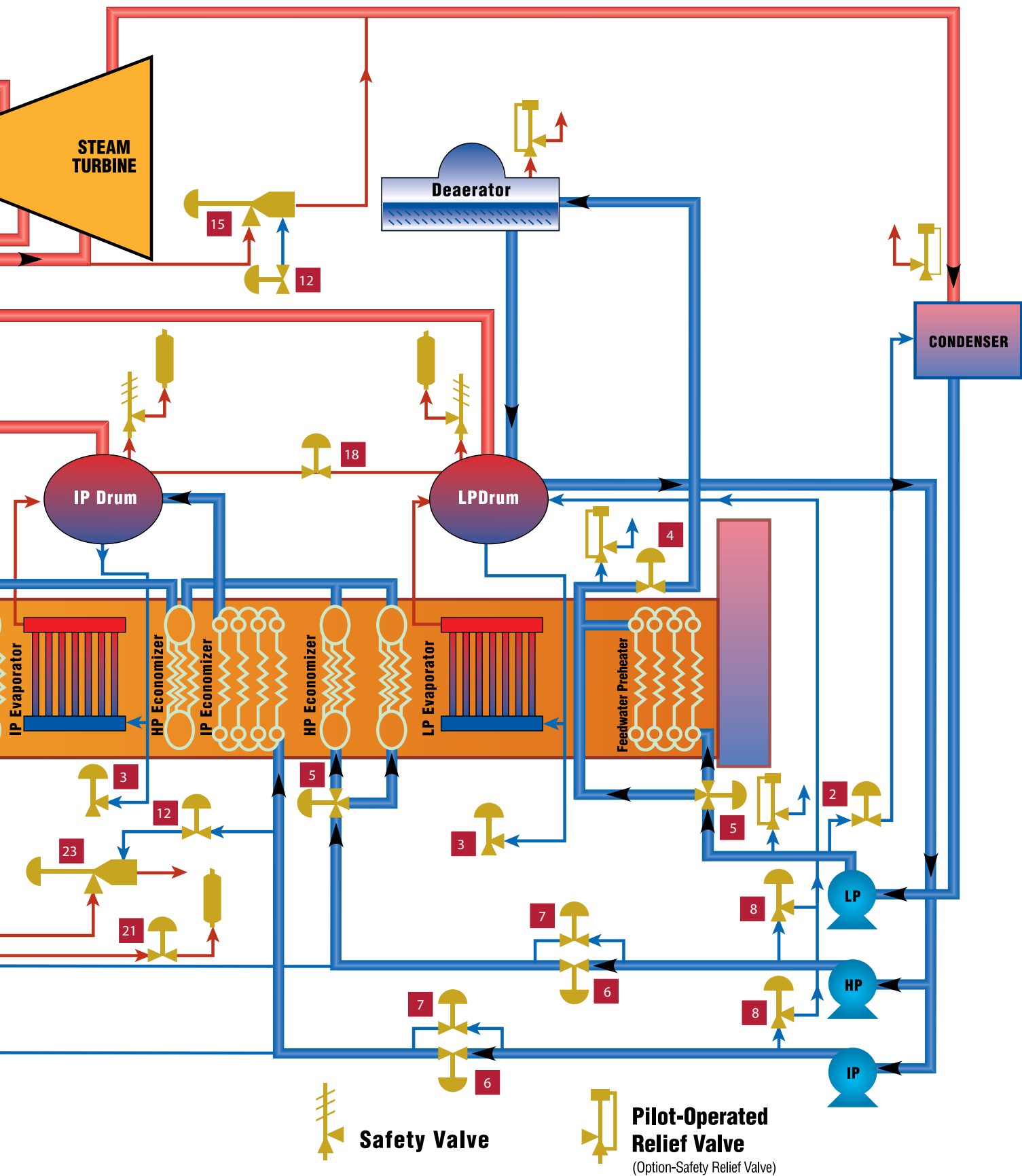

Fossil Fuel Power Plant Typical Applications

Applications	Key Considerations	Valve Recommendations	Page	
Auxiliary Systems				
1	Fuel Oil or Gas Control	Large Flows, Wide Control Range, Noise	35002 <i>Camflex</i> [™]	18
			21000, 41005	12, 14, 17
2	Air Damper	Precision Control, Diagnostics Feedback	SVI [™] II AP & SVI FF	23
Condensate System				
3	Condensate Recirculation	Flashing, Erosion, Cavitation, Tight Shutoff	21000 (1 or 2 Stage Anti-Cavitation Trim)	13
			41005 (1 or 2 Stage Anti-Cavitation Trim)	14-15
4	Deaerator Level Control	Large-Load Fluctuation, Low-Load Cavitation, High Rangeability	41005 (1 or 2 Stage Characterized Anti-Cavitation Trim)	14-15
5	Cond./BFW Continuous Heater Drain	Saturated Water, Flashing, Erosion	35002 <i>Camflex</i> (Low Pressure)	18
			21000A (High Pressure)	12-13
6	Cond./BFW Emergency Heater Drain	Tight Shutoff, High Erosion, Flashing Water	41005	14-15
BFW System				
7	Boiler Feed Pump Recirculation	High-Pressure Drops, Cavitation, Erosion, Tight Shutoff	78400/18400 <i>LincolnLog</i> [™]	21
			41005 (VRT [™] Type C Trim)	14-15
8	Main Feedwater Regulator	High Pressure, Varying Pressure Drops, Large Flows	41005 Standard Trim (VRT Type S Partial Stack Trim or 1/2 Stage Characterized Anti-Cavitation Trim)	14-15
9	Start-up Feedwater Regulator	High-Pressure Drops, Cavitation, Vibration	78400/18400 <i>LincolnLog</i>	21
			41005 (VRT Type C Trim)	14-15
10	Superheater Attemperator Spray	High Pressure, High Rangeability, Tight Shutoff	21000, 41005	12-15
			78400/18400 <i>LincolnLog</i>	21
11	Reheater Attemperator Spray	High Pressure Drop, High Rangeability, Tight Shutoff, Cavitation	21000, 78400/18400 <i>LincolnLog</i>	12, 21

Fossil Fuel Power Plant Typical Applications

Applications	Key Considerations	Valve Recommendations	Page	
BFW System (cont.)				
12	Turbine Bypass Attenuation	High-Pressure Drop, High Rangeability, Tight Shutoff, Cavitation	21000, 41005	12-15
			78400/18400 LincolnLog	21
13	Spraywater Isolation Valves	High Pressure, Tight Shutoff	21000, 41005	12-15
14	HP Economizer/FW Preheater Bypass	Large Flow, High Pressure	80000	16
15	Heater Level Control System	High-Pressure Drop High Rangeability Cavitation, Level Fluctuation	21000, 41005, 12400 DLT/C	12-15, 22
Steam System				
16	Auxiliary Steam	High Pressure/High-Pressure Drops, High Temperature, Wide-Load Fluctuation, High Noise	48000	20
			41005 (1 or 2 Stage Lo-dB Trim)	14-15
			21000 (1 or 2 Stage Lo-dB Trim)	12-13
17	Soot Blower	High Cycle, High Temperature, High Flow Rates, High Pressure, Tight Shutoff	48000	20
			41005 (1 or 2 Stage Lo-dB Trim)	14-15
			21000 (1 or 2 Stage Lo-dB Trim)	12-13
18	HP Turbine Bypass	High Pressure/High-Pressure Drops, High Temperature, Tight Shutoff, High Noise	48000	20
			41005 (1 or 2 Stage Lo-dB Trim)	14-15
			84003 SteamForm™	21
19	IP/LP Turbine Bypass	Moderate Pressure/Large Flows, High Temperature, Tight Shutoff, High Noise	41005 (1 or 2 Stage Lo-dB Trim)	14-15
			84003 SteamForm	21
20	Main/Reheat Steam and Turbine Drains	High Pressure, Tight Shutoff, Erosion	21000, 21000A	12
21	Turbine Seal Pressure	High-Pressure Drop, Noise, High Rangeability	21000, 41005	12-15
22	Deaerator Pegging Steam	Noise, Wide Rangeability, Erosion, Saturated Steam	41005 (1 or 2 Stage Lo-dB Trim)	14-15
			48000	20

Combined-Cycle Power Plant Typical Applications

Applications	Key Considerations	Valve Recommendations	Page	
Auxiliary Systems				
1	Fuel Gas Control	Large Flows, Wide Control Range, Noise	35002 Camflex II	18
			21000, 41005	12, 16, 17
Condensate System				
2	Condensate Pump Recirculation	Flashing, Erosion, Cavitation, Tight Shutoff	21000 (1 or 2 Stage Anti-Cavitation Trim)	12-13
			41005 (1 or 2 Stage Anti-Cavitation Trim)	14-15
3	HP/IP/LP Cond. Blowdown	Saturated Water, Flashing, Erosion	21000A (Stellite Venturi)	12-13
			35002 Camflex II (Stellite Venturi)	18
4	Deaerator Level Control	Large-Load Fluctuation, Low-Load Cavitation, High Rangeability	41005 (1 or 2 Stage Characterized Anti-Cavitation Trim)	14-15
BFW System				
5	HP Economizer/FW Preheater Bypass	Large Flow, High Pressure	80000	16
6	HP/IP/LP Boiler Drum Level Control	High Pressure, Varying Pressure Drops, Large Flows	41005 Standard Trim (VRT Type S or ½ Stage Characterized Anti-Cavitation)	14-15
7	HP/IP Startup Boiler Drum Level Control	High-Pressure Drops, Cavitation, Vibration	78400/18400 LincolnLog	21
			41005 (VRT Type C Trim)	14-15
8	HP/IP Boiler Feedpump Recirculation	High-Pressure Drops, Erosion Cavitation, Tight Shutoff	78400/18400 LincolnLog	21
			41005 (VRT Type C Trim)	14-15
9	Superheater Attemperator Spray	High Pressure, High Rangeability, Tight Shutoff	21000, 41005	12-15
			78400/18400 LincolnLog	21
10	Reheater Attemperator Spray	High-Pressure Drop, High Rangeability, Tight Shutoff, Cavitation	21000, 41005	12-15
			78400/18400 LincolnLog	21
11	Spraywater Isolation Valves	High Pressure, Tight Shutoff	21000, 41005	12-15
12	Turbine Bypass Attemperation	High-Pressure Drop, High Rangeability, Tight Shutoff, Cavitation	21000, 41005	12-15
			78400/18400 LincolnLog	21

Combined-Cycle Power Plant Typical Applications

Applications	Key Considerations	Valve Recommendations	Page		
Steam Systems					
13	Process Steam PRV	High Pressure/High-Pressure Drops, High Temperature, Wide-Load Fluctuation, High Noise	48000	20	
			41005 (1 or 2 Stage Lo-dB Trim)	14-15	
14	HP Turbine Bypass	High Pressure/High-Pressure Drops, High Temperature, Tight Shutoff, High Noise	48000	20	
				41005 (1 or 2 Stage Lo-dB Trim)	14-15
				84003 SteamForm	21
15	IP/LP Turbine Bypass	Moderate Pressure/Large Flows, High Temperature, Tight Shutoff, High Noise	41005 (1 or 2 Stage Lo-dB Trim)	14-15	
				84003 SteamForm	21
16	Main/Reheat Steam and Turbine Drains	High Pressure, Tight Shutoff, Erosion	21000, 21000A	12-13	
17	Turbine Seal Pressure	High-Pressure Drop, Noise, High Rangeability	21000, 41005	12-15	
18	LP Pegging Steam	Noise, Erosion, Wide Rangeability, Saturated Steam	41005 (1 or 2 Stage Lo-dB Trim)	14-15	
19	Superheat Atmospheric Vent	High Pressure/High-Pressure Drops, High Temperature, High Noise/Velocity, Trash	48000	20	
				41005 (1 or 2 Stage Lo-dB Trim w/silencer)	14-15
20	Reheat Atmospheric Vent	Moderate Pressure/ High-Pressure Drops, High Temperature, High Noise/Velocity, Trash	41005 (1 or 2 Stage Lo-dB Trim w/silencer)	14-15	
21	LP Process Tie-In Atmospheric Vent	Large Flow Rates, High Noise/Velocity, Trash	41005 (1 or 2 Stage Lo-dB Trim w/silencer)	14-15	
22	IP Superheat Stm. To Cold Reheat	Moderate Pressure, High Temperature, Wide Load Fluctuation, High Noise	41005	14-15	
23	LP Process Tie-In	Low Pressure, Large Flow Rates High Noise	84003 SteamForm	21	

Power Industry Solutions

Reciprocating Control Valves

21000 Series Top-Guided Globe/Angle Valve

The 21000 series single-ported, heavy top-guided control valves are designed with the versatility to handle a wide variety of power process applications. This includes optional trim designs for anti-cavitation and noise reduction.

Sizes:	3/4" through 8"
ANSI Ratings:	Class 150 through 2500
ANSI Leakage:	Class IV, V, VI
Cv Range:	.11 to 640
Temperature Range:	-150°F to 1050°F
Materials:	Carbon Steel, stainless steel, chrome-moly, other alloys
Connections:	NPT, flanged, socket weld, butt weld
Actuators:	Multi-spring diaphragm, piston cylinder
Applications:	Low pressure steam & water, general services, flash tank, fuel gas, condensate recirculation, superheater and reheat spray, desuperheater water spray, gland-steam pressure, soot blower, steam pressure, auxiliary steam

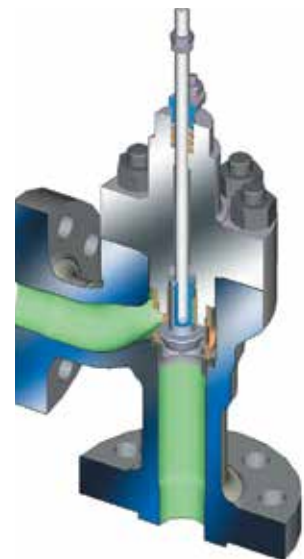
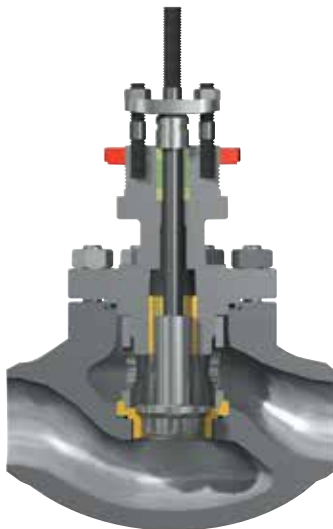

Heavy Top-Guiding

- Larger post-guide area vs. other globe valve designs
- Located away from flowstream
- Providing better stability and control

Various Trim Options

- Single- and double-stage low-noise and anti-cavitation trim
- Hardened-trim standard
- Quick-change or threaded-seat rings
- Reduced-capacities and microflow trim
- Equal percentage and linear contours
- Stellite Venturi seat
- Soft seat design

Design Flexibility

- Multiple-end connections
- Various materials
- Angle-body configuration
- Bellows seal design
- Piston-actuation option
- Extension bonnet
- Low-emission packing
- DIN version available



Specifications	Lo-dB	Anti-Cavitation
Sizes:	3/4" through 6"	3/4" through 4"
ANSI Ratings:	Class 150 through 2500	Class 150 through 2500
Single Stage:	4 to 200	4 to 200
2 Stage:	3.5 to 125	2.3 to 62

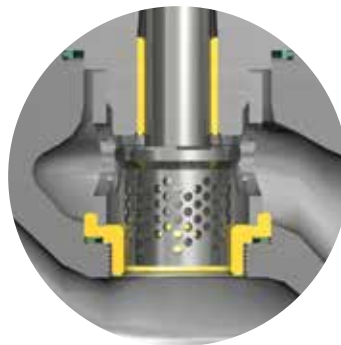

Single Stage Anti-Cavitation Trim/Lo-dB trim

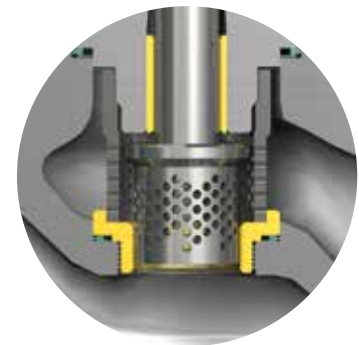

2 Stage Anti-Cavitation Trim/Lo-dB trim



Power Industry Solutions

Reciprocating Control Valves

41005 Series - Cage-Guided Globe/Angle Valve

The 41005 series cage-guided control valves are designed for high performance and to exceed the limits of other conventional valves. With numerous trim configurations (including Lo-dB and anti-cavitation) and the ability to handle large pressure drops, the 41000 Series can be applied in a variety of severe services.

Sizes:	2" through 24"
ANSI Ratings:	Class 150 through 2500
ANSI Leakage:	Class III, IV, V
Cv Range:	10 to 6600
Temperature Range:	-320°F to 1050°F
Materials:	Carbon Steel, stainless steel, chrome-moly, other alloys
Connections:	NPT, flanged, socket weld, butt weld
Actuators:	Multi-spring diaphragm, piston cylinder
Applications:	Auxiliary steam, boiler feedwater, condensate recirculation, deaerator pegging steam, deaerator level control, turbine bypass, and soot blower

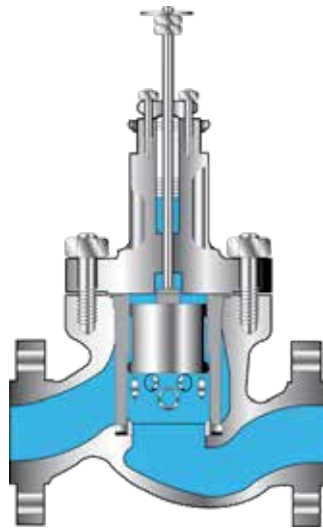

BFW Feedwater Control Valve Trim

Trim Options

VRT Type S Stack Trim

Well-suited for incompressible fluids, such as feed-pump recirculation, injection-valve bypass, and boiler feedwater. Engineered to provide anti-cavitation for applications with pressure drops of up to 6000 psi.

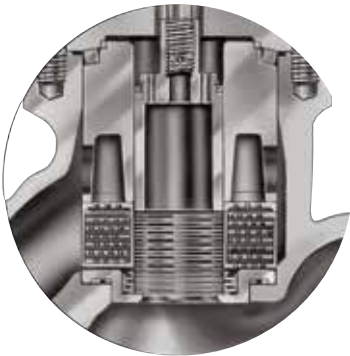

VRT Type S Trim

VRT Type C Cage Trim

Designed to handle high pressure drops in severe-service applications for incompressible fluids. Complete cavitation protection is available for pressure drops up to 3000 psi.

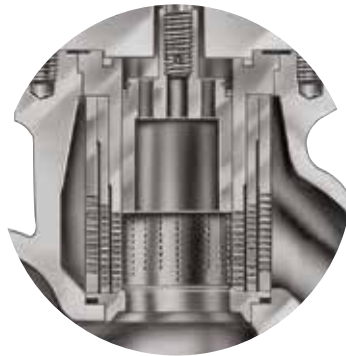

VRT Type C Trim

Single-Stage Trim

Providing excellent noise attenuation on gas or steam services and cavitation protection on liquid services.



Lo-dB Single-Stage Trim

Multi-Stage Trim

Providing excellent noise attenuation on gas or steam services and cavitation protection on liquid services.

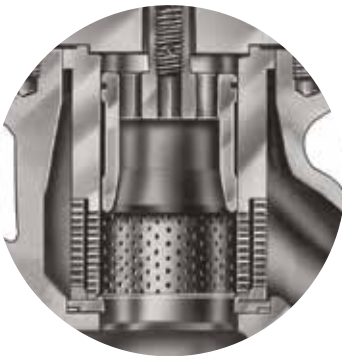

Lo-dB Double-Stage Trim

Pilot-Balanced Trim

Providing tight shut-off on liquid, gas, or steam services.

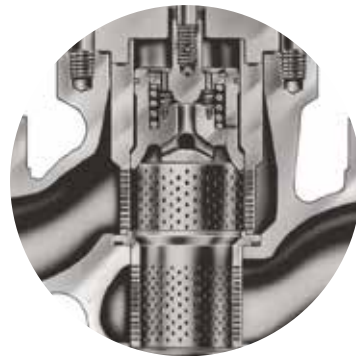

Pilot Trim

Power Industry Solutions

Reciprocating Control Valves

80000 Series

3-Way Diverting or Combining Valve

The 80000 Series is a three-way control valve designed for either combining or diverting applications. It is well-suited for applications requiring high capacities with low-pressure recovery.

Sizes:	1" through 10"
ANSI Ratings:	Class 150 through 2500
ANSI Leakage:	Class II, III, IV
Cv Range:	9 to 750
Temperature Range:	-20°F to 850°F
Materials:	Carbon Steel, stainless steel
Connections:	Flanged, socket weld, butt weld, RJT, threaded
Actuators:	Multi-spring diaphragm, piston cylinder
Applications:	Heat exchangers

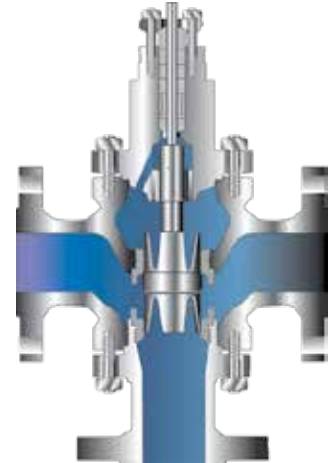



Power Industry Solutions Rotary Control Valves

35002 Series Camflex II Eccentric Plug

As the original eccentric-plug rotary valve, the Camflex combines top performance and features with an extremely economical design. The Camflex, which offers enormous versatility and broad application, remains the most widely used eccentric-plug control valve in the world and now features the EF seal solution to reduce fugitive emissions.

Sizes:	1" through 16"
ANSI Ratings:	Class 150 through 600
ANSI Leakage:	Class IV, VI
Cv Range:	2.8 to 3650
Materials:	Carbon steel, stainless steel, chrome moly
Connections:	NPT, flangeless bolted, flanged
Actuators:	Spring-diaphragm, pneumatic cylinder
Applications:	Heater drain, general service, low pressure steam, flash tank



36005 Series V-Max™ Control Ball

The 36005 V-Max is a high-capacity, control-ball valve with a patented dual-characterized, segmented-ball design combining high-Cv ratings with exceptional 500:1 turndown. It is an excellent solution for both high-viscosity fluid applications (i.e. pulp and paper industry) as well as processes requiring very high capacity balanced with accurate control. Standard features also include the environmental packing (EF) seal.

Sizes:	1" through 12"
ANSI Ratings:	Class 150 through 300
ANSI Leakage:	Class IV or VI
Cv Range:	55 to 4400
Materials:	Carbon steel, stainless steel
Connections:	Flanged
Actuators:	Spring-diaphragm, Scotch yoke cylinder
Applications:	High-viscosity fluid and high-capacity applications.



33000 Series Triple Offset Butterfly Valve

The 33000 Series Triple Offset Butterfly Valve incorporates new performance enhancing operational features, allowing for a more simplified manufacturing process. The result is exclusive patented range of superior performance zero leakage bi-directional triple offset butterfly valves, suitable for extreme pressure/temperature applications.

Sizes:	3" through 48"
ANSI Ratings:	Class 150 through 600
ANSI Leakage:	Class IV, V, VI and API 598
Cv Range:	98 to 66,400
Materials:	Carbon steel, Stainless steel, Duplex
Connections:	Wafer, Lugged, Double Flanged Short & Long Pattern
Actuators:	Model 31/32 Spring Diaphragm, Model 33 Spring Diaphragm
Applications:	High-viscosity fluid and high-capacity applications



39003 Series High-Performance Butterfly Valve

The Masoneilan 39003 Series High-Performance Butterfly Valve (HPBV) is designed for exceptional performance, application flexibility and long service life. This automatic-throttling control valve offers benefits such as enhanced sealing, double-offset operation, excellent flow characteristics, accurate positioning, and dynamic operation.

Sizes:	3" through 48"
ANSI Ratings:	Class 150 through 600
ANSI Leakage:	Class IV or VI
Cv Range:	185 to 91000
Materials:	Carbon steel, stainless steel
Connections:	Flangeless, Lugged, Double Flanged
Actuators:	Spring diaphragm, Pneumatic rack and pinion, Scotch yoke cylinder
Applications:	High-viscosity fluid and high-capacity applications.



Power Industry Solutions

Severe Service Control Valves

48000 Series Cage-Guided Control Valve

The 48000 Series control valves are designed especially for high-temperature and high-pressure steam services where the cages tend to be deformed due to high heat-cycle frequency or thermal stress from sudden changes in temperature.

Sizes:	2" through 10"
ANSI Ratings:	1500 through 2500
ANSI Leakage:	Class II, III, IV, V
Cv Range:	3.8 to 640
Materials:	Carbon steel, Chrome-moly, Low-alloy steel
Connections:	SW, BW, flanged (RF, RTJ)
Actuators:	Cylinder
Applications:	Turbine bypass, boiler auxiliary steam pressure, turbine-gland steam pressure, soot-blower steam pressure, main air-ejector steam pressure

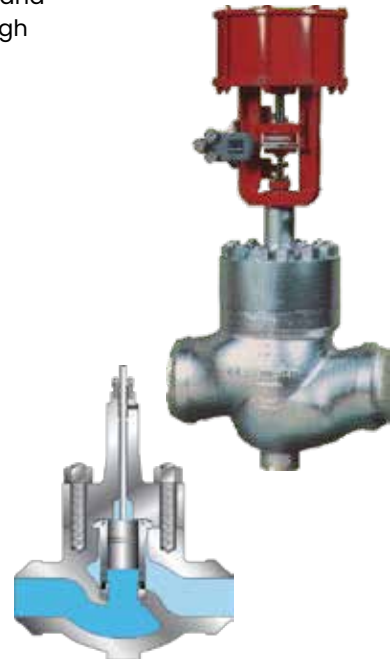

49000 Series Globe and Angle Style with Lo-dB or V-Log™ Trim

The 49000 Series is designed with enlarged body galleries to accommodate large stroke lengths and up to 36 stages of pressure reduction.

Sizes:	4" through 36"
ANSI Ratings:	Class 150 through 2500 UNI-DIN 10 through 400
ANSI Leakage:	Class III, IV or V
Cv Range:	6 to 4,910
Materials:	Carbon steel, stainless steel, chrome-moly
Connections:	Flanged, BW
Actuators:	Multi-spring, piston cylinder
Applications:	Boiler feed water-start-up and control, steam letdown, pump-discharge, water-reinjection, gas-recycle and vent applications



78400/18400 Series LincolnLog

The Masoneilan LincolnLog is the premier high-pressure liquid-letdown valve in the process control industry. It is a field proven severe-service solution for cavitating and erosive applications in various industries. The LincolnLog is uniquely designed to operate reliably in harsh environments and dirty liquids.

Sizes:	1" through 8"
ANSI Ratings:	Class 600 through 2500
ANSI Leakage:	Class IV, V or VI
Cv Range:	0.5 to 135
Materials:	Carbon steel, 316 stainless steel, chrome-moly, others
Connections:	RFF, RTJ, socket weld, butt weld, threaded-print flanges (forgings)
Actuators:	Multi-spring diaphragm, piston cylinder
Applications:	Cavitating and erosive applications in various industries



79003 Series Angle Style with VRT Trim

The 79003 Series valves are designed for anti-cavitation service with control over a wide range of operating conditions, such as the ramp-up transition of a normal feedwater pump.

Sizes:	1" through 6"
ANSI Ratings:	Class 600 through 2500 UNI-DIN 100 through 400
ANSI Leakage:	V or VI
Cv Range:	2 to 105
Materials:	Carbon Steel, stainless steel, chrome-moly
Connections:	Flanged, butt weld
Actuators:	Multi-spring diaphragm, piston cylinder
Applications:	Feedwater control, feedwater pump start-up valve



84003 Series SteamForm

The 84003 Series SteamForm is designed with a wide range of features including a patented water-injection system for best performance in steam-conditioning applications.

Sizes:	Trim: 3" through 24" Pipe: 3" through 48"
ANSI Ratings:	Class 150 through 2500 UNI-DIN 10 through 400
ANSI Leakage:	Class II, III, IV, or V
Cv Range:	25 to 6,740
Materials:	Carbon Steel, Chrome-moly
Connections:	Flanged, butt weld
Actuators:	Spring-diaphragm, piston cylinder
Applications:	Turbine bypass, Process steam conditioning



Power Industry Solutions Smart Instrumentation

SVI1000 – Digital Valve Positioner

The SVI1000 is a user-friendly 4–20mA with HART® digital valve positioner for single-acting pneumatic control valves. Leveraging many of the same technologies from the SVI II AP, the SVI1000 is perfect for those that need a low maintenance valve positioner, and an ideal candidate for upgrading legacy electro-pneumatic positioners. Designed to be installed and operational in less than 5 minutes, the SVI1000 is easily through its “One button, one function” local pushbuttons or via its powerful DTM interface and ValVue™ software.



Communication Platform:	HART®	
Signal – Supply:	4–20 mA control signal	
	No external power required	
	Supply pressure:	20 – 100 psi, (1.4 – 7 bar)
Communication Software Interface:	<ul style="list-style-type: none"> • ValVue standalone • Integrated (PLUG-IN, SNAP-ON, FDM) • eDDL or DTM 	
Hazardous Area Certifications:	ATEX, FM, IEC, CU TR, KOSHA approvals	

SVI II AP – Advanced Performance Digital Positioner

The Masoneilan Smart Valve Interface Advanced Performance (SVI II AP) product is an intelligent digital valve positioner. SVI II AP offers advanced control technology for pneumatically actuated valves with a non-contact Hall Effect sensor, providing higher precision and reliability, greater flexibility and ease of use. ValVue 3 is a communication software tool used to configure, calibrate and perform valve diagnostics with the SVI II AP utilizing HART® communications protocol.



Communication Platform:	HART®	
Signal – Supply:	4–20 mA control signal	
	No external power required	
	Supply pressure:	20 – 100 psi, (1.4 – 7 bar)
Communication Software Interface:	<ul style="list-style-type: none"> • ValVue 3 standalone • Integrated (PLUG-IN, SNAP-ON, FDM) • eDDL or DTM 	
Hazardous Area Certifications:	ATEX, FM, IEC, CU TR, KOSHA approvals	

SVI FF Advanced FOUNDATION® Fieldbus Positioner

The SVI FF is an advanced performance positioner with FOUNDATION® protocol, for single and double-acting pneumatic control valves, its universal and modular design with a proven non-contact position sensor fits many applications, offering high performance valve control with real-time diagnostics.



Communication Platform:	FOUNDATION® Fieldbus	
Input Signal:	FOUNDATION® Fieldbus	
	No external power required	
	Supply pressure: (single and double acting)	20 – 150 psi (1.4 – 10.3 bar)
Communication Software Interface:	<ul style="list-style-type: none"> • ValVue FF standalone • Integrated (PLUG-IN, SNAP-ON) • eDDL or DTM 	
Hazardous Area certifications:	<ul style="list-style-type: none"> • ATEX, FM, CU TR, KOSHA, NEPSI, INMETRO and CSA approvals • Explosion proof & intrinsically safe 	

Level Transmitter/Controller

12400 Series Digital Level Transmitter/Controller

The Masoneilan 12400 Series Instrument is a two-wire, loop-powered digital displacement-type level transmitter or controller with HART® Communication. This high-performance instrument is easily set up and calibrated by using either ValVue communication software, EDDL, DTM, a hand-held communicator, or local pushbuttons and digital display. This versatility allows the operator to configure, calibrate, and perform other functions either at the instrument or from the control room.

Range:	14" through 120", (355 through 3048 mm)	
Ratings and Connections:	Flanged:	ANSI 150 - 2500
		UNI-DIN 10 - 100
	Screwed:	NPT-F (1.5", 2")
	Welded	
Body Materials:	Carbon steel	
	Stainless steel	
	Chrome-moly	
Displacer Materials:	Stainless steel	
	Other materials on request	
Torque Tube Materials:	Inconel	
	Stainless steel	
	Other materials on request	
Electronic Instrument:	HART® protocol	
	4 - 20 mA signal	
	ATEX, FM, JIS, CU TR, CSA, CRN, IEC, INMETRO, CCOE, NEPSI, IA, TAIWAN TS between main approvals	

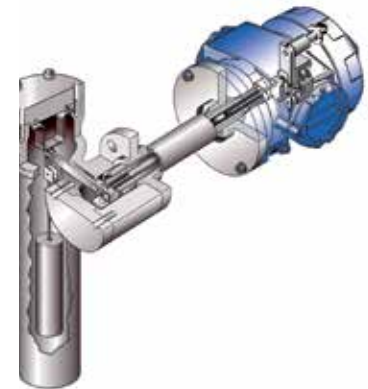

ValVue 3 Device Diagnostics & Configuration Tool

Key Features:

- Common interface for all instruments
- Time stamped Audit Trail provides full documentation of all changes managed by the application
- Automatic device monitoring with NAMUR 107 compliant alerts
- Provide specific task authorization with user level access control
- Easy PDF Report generation

Benefits:

- Automates standard device commissioning steps with Sequencer to get more done, consistently and accurately
- Enables easy compliance validation for audit reports
- Enhances security by requiring user authentication
- Shorter training cycles by using the same basic interface for all field devices

ValVue 3 is powerful and user-friendly interface designed for set-up and diagnostics of control valves equipped with an SVI II AP, SVI1000, SVI FF, SVI II ESD, FVP or 12300/12400 Digital Level Transmitters/Controllers. ValVue enhances the diagnostics capabilities of your control valves and improves asset efficiency when setting up a digital valve positioner or level transmitter. It offers electronic documentation of configuration and calibration results as well as valve signature analysis. These solutions reduce the complexity in commissioning Foundation Fieldbus or HART digital valve positioners and transmitters.

Direct Sales Office Locations

Australia

Brisbane
Phone: +61-7-3001-4319

Perth
Phone: +61-8-6595-7018

Melbourne
Phone: +61-3-8807-6002

Brazil

Phone: +55-19-2104-6900

China

Phone: +86-10-5738-8888

France

Courbevoie
Phone: +33-1-4904-9000

India

Mumbai
Phone: +91-22-8354790

New Delhi

Phone: +91-11-2-6164175

Italy

Phone: +39-081-7892-111

Japan

Tokyo
Phone: +81-03-6871-9008

Korea

Phone: +82-2-2274-0748

Malaysia

Phone: +60-3-2161-03228

Mexico

Phone: +52-55-3640-5060

Russia

Veliky Novgorod
Phone: +7-8162-55-7898

Moscow

Phone: +7-495-585-1276

Saudi Arabia

Phone: +966-3-341-0278

Singapore

Phone: +65-6861-6100

South Africa

Phone: +27-11-452-1550

South & Central America and the Caribbean

Phone: +55-12-2134-1201

Spain

Phone: +34-935-877-605

United Arab Emirates

Phone: +971-4-8991-777

United Kingdom

Phone: +44-7919-382-156

United States

Houston, Texas

Phone: +1-713-966-3600

Find the nearest local Channel Partner in your area:
valves.bakerhughes.com/contact-us

Tech Field Support & Warranty:

Phone: +1-866-827-5378
valvesupport@bakerhughes.com

valves.bakerhughes.com

Baker Hughes 