

# Mooney™ Series 20 Relief Valve

Instruction Manual (Rev.C)

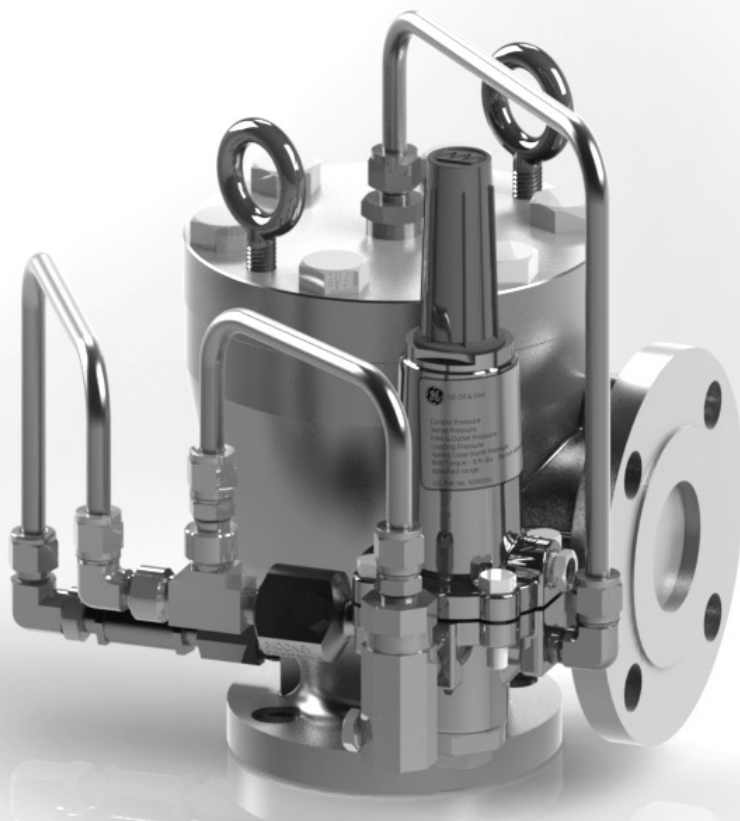

**THESE INSTRUCTIONS PROVIDE THE CUSTOMER/OPERATOR WITH IMPORTANT PROJECT-SPECIFIC REFERENCE INFORMATION IN ADDITION TO THE CUSTOMER/OPERATOR'S NORMAL OPERATION AND MAINTENANCE PROCEDURES. SINCE OPERATION AND MAINTENANCE PHILOSOPHIES VARY, BAKER HUGHES COMPANY (AND ITS SUBSIDIARIES AND AFFILIATES) DOES NOT ATTEMPT TO DICTATE SPECIFIC PROCEDURES, BUT TO PROVIDE BASIC LIMITATIONS AND REQUIREMENTS CREATED BY THE TYPE OF EQUIPMENT PROVIDED.**

**THESE INSTRUCTIONS ASSUME THAT OPERATORS ALREADY HAVE A GENERAL UNDERSTANDING OF THE REQUIREMENTS FOR SAFE OPERATION OF MECHANICAL AND ELECTRICAL EQUIPMENT IN POTENTIALLY HAZARDOUS ENVIRONMENTS. THEREFORE, THESE INSTRUCTIONS SHOULD BE INTERPRETED AND APPLIED IN CONJUNCTION WITH THE SAFETY RULES AND REGULATIONS APPLICABLE AT THE SITE AND THE PARTICULAR REQUIREMENTS FOR OPERATION OF OTHER EQUIPMENT AT THE SITE.**

**THESE INSTRUCTIONS DO NOT PURPORT TO COVER ALL DETAILS OR VARIATIONS IN EQUIPMENT NOR TO PROVIDE FOR EVERY POSSIBLE CONTINGENCY TO BE MET IN CONNECTION WITH INSTALLATION, OPERATION OR MAINTENANCE. SHOULD FURTHER INFORMATION BE DESIRED OR SHOULD PARTICULAR PROBLEMS ARISE WHICH ARE NOT COVERED SUFFICIENTLY FOR THE CUSTOMER/OPERATOR'S PURPOSES THE MATTER SHOULD BE REFERRED TO BAKER HUGHES.**

**THE RIGHTS, OBLIGATIONS AND LIABILITIES OF BAKER HUGHES AND THE CUSTOMER/OPERATOR ARE STRICTLY LIMITED TO THOSE EXPRESSLY PROVIDED IN THE CONTRACT RELATING TO THE SUPPLY OF THE EQUIPMENT. NO ADDITIONAL REPRESENTATIONS OR WARRANTIES BY BAKER HUGHES REGARDING THE EQUIPMENT OR ITS USE ARE GIVEN OR IMPLIED BY THE ISSUE OF THESE INSTRUCTIONS.**

**THESE INSTRUCTIONS ARE FURNISHED TO THE CUSTOMER/OPERATOR SOLELY TO ASSIST IN THE INSTALLATION, TESTING, OPERATION, AND/OR MAINTENANCE OF THE EQUIPMENT DESCRIBED. THIS DOCUMENT SHALL NOT BE REPRODUCED IN WHOLE OR IN PART WITHOUT THE WRITTEN APPROVAL OF BAKER HUGHES.**

# I. Product Safety Sign and Label System

If and when required, appropriate safety labels have been included in the rectangular margin blocks throughout this manual. Safety labels are vertically oriented rectangles as shown in the representative examples (below), consisting of three panels encircled by a narrow border. The panels can contain four messages which communicate:

- The level of hazard seriousness
- The nature of the hazard
- The consequence of human, or product, interaction with the hazard.
- The instructions, if necessary, on how to avoid the hazard.

The top panel of the format contains a signal word (DANGER, WARNING, CAUTION or ATTENTION) which communicates the level of hazard seriousness.

The center panel contains a pictorial which communicates the nature of the hazard, and the possible consequence of human or product interaction with the hazard. In some instances of human hazards the pictorial may, instead, depict what preventive measures to take, such as wearing protective equipment.

The bottom panel may contain an instruction message on how to avoid the hazard. In the case of human hazard, this message may also contain a more precise definition of the hazard, and the consequences of human interaction with the hazard, than can be communicated solely by the pictorial.

①

**DANGER** — Immediate hazards which WILL result in severe personal injury or death.

②

**WARNING** — Hazards or unsafe practices which COULD result in severe personal injury or death.

③

**CAUTION** — Hazards or unsafe practices which COULD result in minor personal injury.

④

**ATTENTION** — Hazards or unsafe practices which COULD result in product or property damage.

①

**▲ DANGER**

Do not remove bolts if pressure is in the line, as this will result in severe personal injury or death.

②

**▲ WARNING**

RADIATION AREA  
KEEP OUT  
RWP REQUIRED FOR ENTRY.

Know nuclear "health physics" procedures, if applicable, to avoid possible severe personal injury or death.

③

**▲ CAUTION**

Wear necessary protective equipment to prevent possible injury

④

**▲ ATTENTION**

Do not drop or strike.

## II. Safety Alerts



### Read - Understand - Practice

1. **DANGER:** It is the end users responsibility to ensure proper installation and the associated risks in accordance with API 520 Part 2.
  2. **DANGER:** High temperature/pressure can cause injury. Be sure all system pressure is absent before repairing or removing valve.
  3. **DANGER:** Don't stand in front of valve outlet when discharging. STAND CLEAR OF VALVE to prevent exposure to trapped, corrosive media.
  4. **DANGER:** When inspecting a pressure relief valve for leakage. BE VERY CAREFUL!
- 
1. **WARNING:** Taking the appropriate actions to ensure that site personnel who are performing installation, commissioning, and maintenance have been trained in proper site procedures for working with and around GE supplied equipment, per Safe Site Work Practices, are the end users responsibility.
  2. **WARNING:** Allow the system to cool to room temperature before cleaning, servicing or repairing the system. Hot components or fluids can cause severe personal injury or death.
  3. **WARNING:** Always read and comply with safety labels on all containers. Do not remove or deface the container. Do not remove or deface the container labels. Improper handling or misuse could result in severe personal injury and/or death.
  4. **WARNING:** Never use pressurized fluids/gas/air to clean clothing or body parts. Never use body parts to check for leakage or discharge rates of areas. Pressurized fluids/gas/air injected into or near the body can cause severe personal injury or death.
  5. **WARNING:** It is the responsibility of the owner to specify and provide guarding to protect persons from contact with pressurized or heated parts. Contact with pressurized or heated parts can result in sever personal injury or death.
  6. **WARNING:** Do not allow anyone under the influence of intoxicants or narcotics to work on or around pressurized systems. Workers under the influence of intoxicants or narcotics are a hazard to both themselves and other employees and can cause severe personal injury or death to themselves or others.
  7. **WARNING:** Incorrect service and repair could result in product or property damage and/or serve personal injury or death.
  8. **WARNING:** Use of improper tools or improper use of the right tools could result in personal injury and/or product or property damage.
  9. **WARNING:** Any and all lines and fittings shall be properly connected and secured, and as required anchored to restrict movement.
  10. **WARNING:** Proper Lockout/Tagout of energy sources prior to maintenance, per Safe Site Work Practices, is the end users responsibility. This includes any potential control signals or circuits that may have a remote or automated control function over any product.

## II. Safety Alerts (Contd.)

**⚠ WARNING**



All potential hazards may not be covered in this manual.

**⚠ WARNING**



Improper tools or improper use of the right tools could result in personal injury or product damage.

**⚠ WARNING**

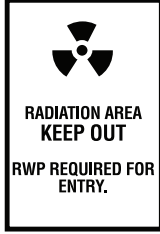

Know nuclear "health physics" procedures, if applicable, to avoid possible severe personal injury or death.

**⚠ CAUTION**



Heed all service manual warnings. Read installation instructions before installing valve(s).

**⚠ CAUTION**



Wear necessary protective equipment to prevent possible injury

**⚠ CAUTION**



Always use appropriate restoration procedures.

11. **WARNING:** After installation or maintenance, it is the end users responsibility to ensure the equipment has been properly inspected and returned to proper condition before being returned to service.
  12. **WARNING:** It is the end users responsibility to ensure properly loaded and/or supported piping to avoid undesired stresses on the product which may result in damage to the product, loss of containment, or loss of functionality and resulting unsafe states or conditions.
  13. **WARNING:** It is the end users responsibility to correctly identify end locations and place product in areas that do not contain explosive atmospheres.
  14. **WARNING:** The failure of properly following the test, installation, maintenance and/or disassembly/assembly instructions may result in a compromised product which in turn could result in an uncontrolled/unexpected loss of containment and release of pressure and heated flammable gas. It is the responsibility of the person conducting the tasks listed above to take great care in following such procedures.
  15. **WARNING:** For products installed in areas with explosive media in the surrounding environment, it is the end users responsibility that only properly trained personnel evaluate, install, and work on such installations, and in accordance with safe site work practices.
  16. **WARNING:** It is the end users responsibility to recognize and safely contain any leak. Failure to do so could result in injury or death..
1. **CAUTION:** Heed all service manual warnings. Read installation instructions before installing valve(s).
  2. **CAUTION:** Ensure proper Personal Protective Equipment is available and used.
  3. **CAUTION:** Wear hearing protection when testing or operating valve(s).
  4. **CAUTION:** Wear appropriate eye and clothing protection.
  5. **CAUTION:** Wear protective breathing apparatus to protect against toxic media.
  6. **CAUTION:** Proper lifting techniques / equipment / procedures (refer to O&M manual for additional information), per Safe Site Work Practices, are the end users responsibility.
  7. **CAUTION:** During assembly or maintenance and under operation in some conditions the operators or technicians should be alert and aware of all possible pinch points or areas where there are moving or sliding components.

# Scope

This manual includes instructions for the installation, operation and maintenance of the Mooney Series 20 Relief Valve. For questions concerning any details of this manual, please contact the manufacturer’s representative or the factory.

## Table of Contents

<b>Product Introduction</b> .....	<b>5</b>
<b>Specifications</b> .....	<b>5</b>
<b>Nameplate Information</b> .....	<b>6</b>
<b>Principle of Operation</b> .....	<b>7</b>
<b>Installation</b> .....	<b>8</b>
<b>Remote Sensing</b> .....	<b>8</b>
<b>Startup and Operation</b> .....	<b>9</b>
<b>General Planning for Maintenance</b> .....	<b>9</b>
<b>Disassembly of the Mooney Series 20 Relief Valve</b> .....	<b>10</b>
Cleaning .....	11
<b>Inspection of the Main Valve</b> .....	<b>11</b>
<b>Reassembly</b> .....	<b>11</b>
Reassembly of Pilot to Main Valve .....	13
<b>Mooney Series 20 Pilot</b> .....	<b>13</b>
Product Description.....	13
General Description .....	13
Pilot Markings (Figure 12).....	15
<b>Maintenance</b> .....	<b>15</b>
<b>Pilot Disassembly</b> .....	<b>16</b>
<b>Pilot Assembly</b> .....	<b>16</b>
<b>Hydrostatic Testing</b> .....	<b>18</b>
<b>Accessories</b> .....	<b>18</b>

# Product Introduction

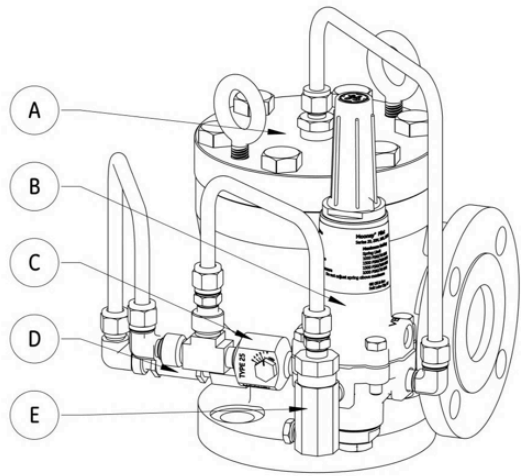

**Figure 1**  
**Mooney Series 20 Relief Valve.**

The Mooney Series 20 Relief Valve included in this manual is an over-pressure protection device designed to be used with a self-contained pilot valve system. This device is intended for use on DOT regulated applications and shall NOT be used to meet the requirements for ASME Section VIII.

The Mooney Series 20 Relief Valve consists of five main components (Figure 1):

## A. Main valve

Available in inlet sizes 1.5” through 8”, with a full-bore orifice, the main valve contains a seat O-Ring to maintain a bubble tight seal and a nozzle O-Ring to isolate the dome from the inlet and outlet ports. Assembly and disassembly of the main valve are accomplished through top entry. When there is no pressure in the system, routine maintenance, such as replacement of O-Rings and seals, may be done with the main valve in place.

## B. Mooney Series 20 or 20H Pilot in Back Pressure (BPV) Mode

The Series 20 Pilot is an independent pneumatically operated flowing auxiliary device intended for controlling the main valve. While the Series 20 Pilot is able to be configured in either pressure reducing or back pressure (BPV) modes, it should only be used in the back pressure (BPV) mode when installed on the Consolidated\* main valve assembly.

## C. Mooney Type 25 Restrictor

Designed exclusively for the Mooney Series 20 Relief Valve, the Type 25 Restrictor has a variably controlled orifice with a range setting of ‘0-5’. Adjustment of the restrictor affects the response rate, stability, and sensitivity of the valve. Smaller restrictor openings result in higher gain (sensitivity) and slower closing speeds. Larger openings result in lower gain (greater proportional band), greater stability and faster closing speeds. The Type 25 Restrictor is required for normal valve operation. The recommended and factory setting for optimal performance is ‘2’.

## D. Inline Filter

A 15 micron inline filter is recommended on all Mooney Series 20 Relief Valves. This inline filter serves to limit debris particles from entering the supply line of the pilot.

## E. Field Test Connection

A field test connection is recommended for the Mooney Series 20 Relief Valve. This allows the stroking of the valve with an auxiliary media, e.g. air or nitrogen in order to establish the desired pressure set point. An internal check valve is present in the field test connection isolating the inlet media from the test media and at the same time, allowing the valve to open normally in the event of a system over pressurization during a field test.

# Specifications

Specifications	
Main Valve Orifice	Full-bore
Sizes	1.5” (40mm) through 8” (200mm) inlet
Body Style	1.5” through 4” Inlet – Single Outlet 6” through 8” Inlet – Dual Outlet
Inlet Ratings	ASME/ANSI Class 150 through 300
Outlet Ratings	ASME/ANSI Class 150
Temperature Range	-20°F to 150°F (-29°C to 66°C)
Pressure Range	15 psig to 740 psig
End Connections	Raised-face flanges
Materials	Carbon Steel or 316 SST Main Valve Brass or SST Pilot

**Table 1**

# Nameplate Information

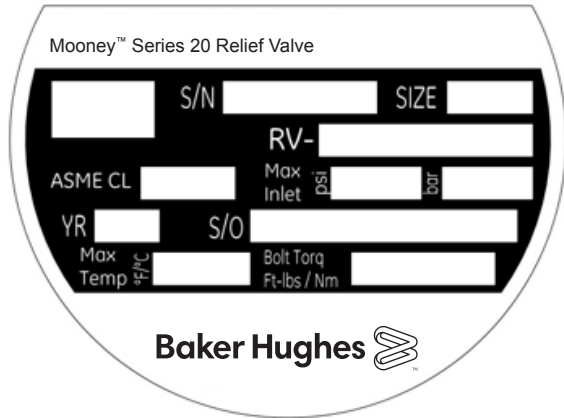

**Figure 2**  
Nameplate of Mooney Series 20 Relief Valve

Designation	Definition
Blank Box	CE Marking
S/N	Serial Number
Size	Line Size of the Valve (Inlet X Outlet)
RV-	Figure Number
ANSI/ASME CL	Inlet Class flange rating
Max Inlet	Maximum Operating Inlet Pressure (psig)
YR	Year Manufactured
S/O	Sales Order Number
Max Temp	Maximum Operating Temperature
Bolt Torq	Recommended Cover Plate Bolt Torque

**Table 2**



# Principle of Operation

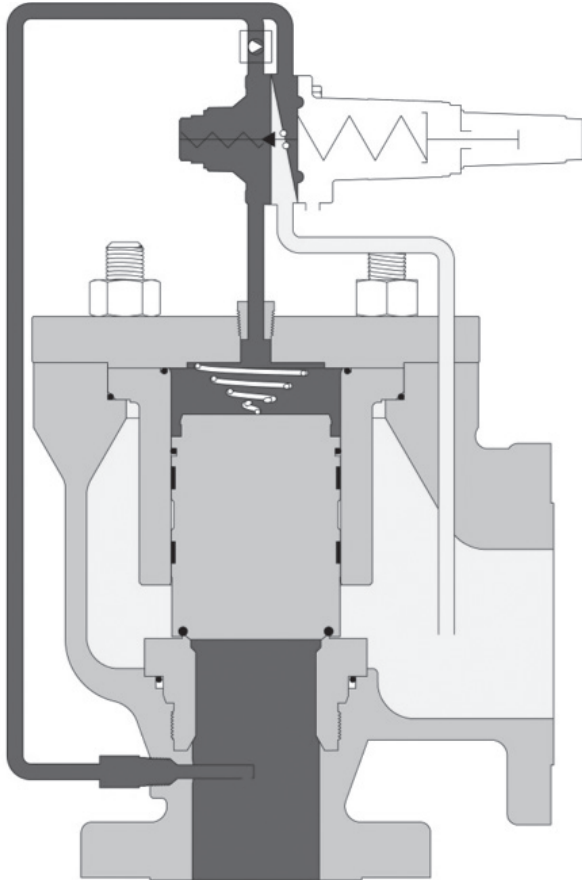

**Figure 3**  
**Closed Position**

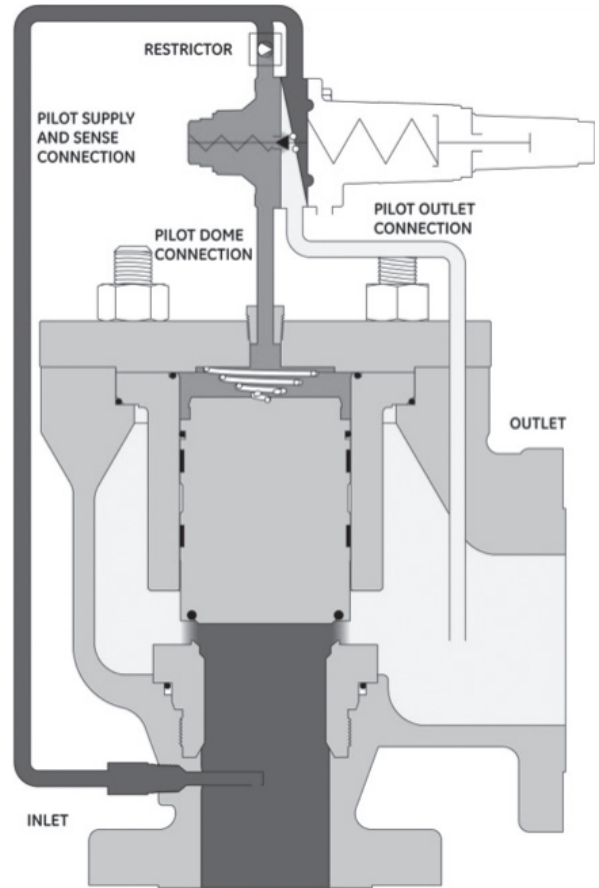

**Figure 4**  
**Partially Open Position**

The Mooney Series 20 Relief Valve controls system pressure upstream of the valve. When system pressure is less than the pilot set point, the pilot venting port is closed, and system pressure from the main valve inlet is fed through the pilot to equalize with the dome pressure. Since the area above the main valve disc is larger than the area of the main valve seating surface, the difference in area causes a net downward force, keeping the main valve closed.

As system pressure increases, system media pushes against the main pilot spring in the pilot sense chamber. The pilot opens and relieves the dome pressure from the relief valve to the outlet faster than is flowing into the dome through the restrictor. As the dome pressure decreases the main valve disc begins to lift with the inlet pressure force. The force balance at this moment is equal between system pressure in the sense chamber and the

main pilot spring. As the pressure increases or decreases within this balance, the pilot's control of flow opens and closes and the dome pressure decreases and increases, respectively, the valve disc responding sensitively to the flow demand.

As inlet pressure increases further, the net upward force on the main valve disc increases, allowing the main valve to relieve more pressure. The disc obtains full lift (full capacity) at 1.5 psig or 5% above set point, whichever is greater.

When discharging, the valve reduces system pressure below the set point, allowing the pilot to reclose. The system pressure continues to flow through the restrictor to equalize with the pressure in the dome above the main valve disc. The downward force created by the difference in areas of the disc allows the disc to close. The disc obtains full reset at 1.5 psig or 5% below set point, whichever is greater.

# Installation

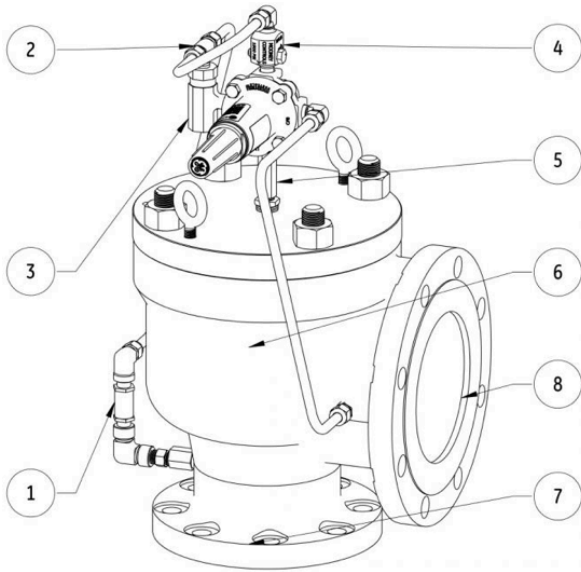

**Figure 5**  
**Mounting Option A**

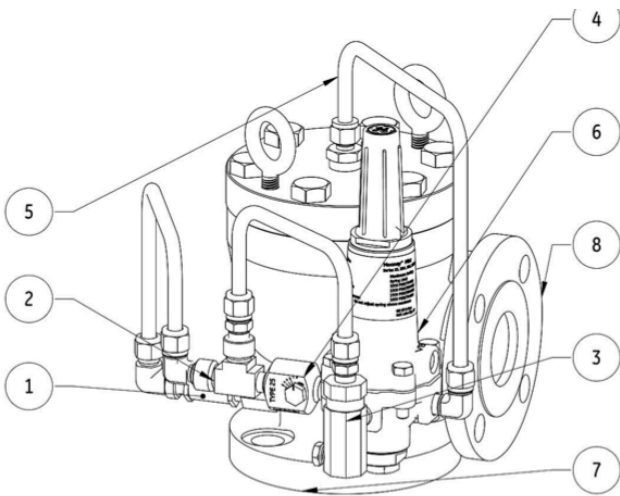

**Figure 6**  
**Mounting Option C**

1. The Filter connects to the Main Valve Inlet Supply via the Inlet Supply Guide
2. Tubing splits from the Filter outlet to the Field Test Connection (if applicable) and Type 25 Restrictor
3. The Field Test Connection (if applicable) connects to the Pilot Sense port
4. The Type 25 Restrictor connects to the Pilot Inlet port
5. The Pilot Loading port connects to the Main Valve Dome port
6. The Pilot Outlet connects to the NPT tapped main valve outlet port
7. Connect the flanged inlet system piping to the upstream inlet flange
8. Connect the flanged outlet system piping to the downstream outlet flange

# Remote Sensing

The Mooney Series 20 Relief Valve ships standard from the factory with the sense line connected to the main valve inlet supply guide. If the pressure drop between the source of pressure in the system or equipment to be protected and the pressure at the relief valve inlet exceeds 3%, the sensing line to the pilot valve can be connected directly to the process system rather than to the main valve. Pipe connections are 1/4" NPT, and tubing connections are 3/8" OD Seamless Stainless Steel.

**ATTENTION:** For remote sensing, 3/8" (9.5 mm) OD tubing is adequate for distances up to 10 feet (3m). Sense line locations should be away from turbulent areas (elbows, valves, reducers, etc.) and have full opening into the pipe free from burrs, drill peels, and weld slag. Shut-off valves are not required, but if used, should be full-bore.

## Mounting Option A (Figures 5 & 7)

1. Remove tubing between the Field Test Connection (B) and the filter (E), leaving NPT connections in place.
2. Connect the filter (E) and the restrictor (A) via new tubing (D).
  - a. Elbow fitting the Type 25 Restrictor must be rotated 180° to perform this action.

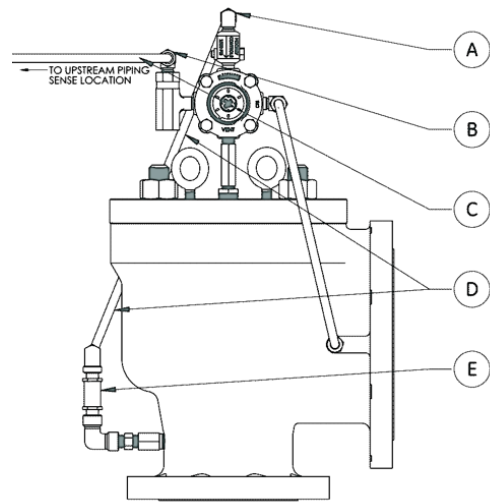

**Figure 7**

3. Place a tubing plug on one of the open tubing connections on the tubing tee above the Field Test Connection (B).
4. Connect remote sense location upstream of the valve to the Field Test Connection (B) via new tubing (C).

## Mounting Option C (Figures 6 & 8)

1. Remove tubing between the field test connections (B) and tee (C), leaving NPT connections in place.
2. Place tubing plug (provided) on exposed tubing connection on tee (C).
3. Connect remote sense location upstream of the valve to the field test connection (B) via new tubing (A).

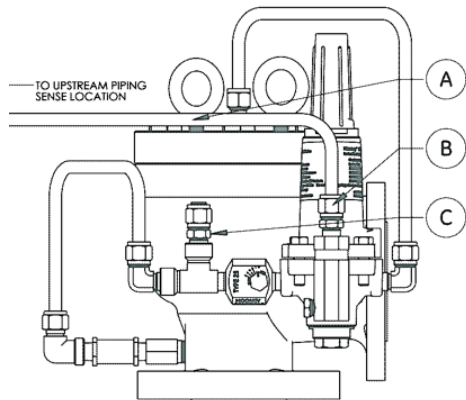

Figure 8

## Startup and Operation



**WARNING:** Ensure the Type 25 restrictor (rounded body) is used. Attempting to operate the relief valve with the Type 24 restrictor (square body) will result in poor performance and/or failure to operate.

**CAUTION:** Adjustment of the restrictor affects the response rate, stability, and sensitivity of the main valve. The recommended and factory setting is “2”.

1. For optimal results, ensure the Type 25 Restrictor is set to “2”.
2. Increase pilot spring compression to the maximum limit or some margin above the desired setting.
3. If installed, open hand valve(s) in the sense line, and the pilot supply line.

4. Ensure the system downstream of the relief valve is ready to accept flow.
5. Slowly open valve upstream to pressurize the relief valve.
  - a. The relief valve should lock-up with zero pressure/flow downstream.
6. If an auxiliary bottle is used (recommended),
  - a. Slowly decrease pilot spring setting until flow is achieved
    - i. The flow may only be through the pilot.
    - ii. If the system is unstable, adjust the restrictor to a higher setting to achieve a more stable flow.
7. Slowly adjust the pilot spring setting until the desired set point is achieved.
  - a. Firmly tighten down locknut to pilot closing cap.

## General Planning for Maintenance

A 12 month maintenance interval is recommended for general service conditions. For severe service applications, a more frequent inspection and testing interim may be more appropriate. Applicable industry regulations and the specific company's operating and service history will better determine this frequency. GE encourages preventive maintenance.

**The Mooney Series 20 Relief Valve is easily maintained. Normal Maintenance usually involves:**

- Removal of pilot valve from main valve
- Disassembly of both the pilot and main valve
- Cleaning
- Component inspection
- Parts replacement (as needed)
- Reassembly
- Setting and testing



# Dissassembly of the Mooney Series 20 Relief Valve

**WARNING:** Before disassembly or maintenance, ensure the main valve and pilot are isolated from the process media by closing block valves on the inlet and outlet sides of the main valve. Safely release pressure and process fluid from the main valve body and pilot system. Failure to properly complete these steps can cause severe personal injury or death.

## Removal of Pilot for Main Valve

- a. Disconnect all tubing connections and remove all tubing.
- b. Remove pilot by turning the pilot counterclockwise.

## Disassembly of the Main Valve

1. Loosen and remove the Nuts (or Cap Screws) on the Cover Plate
2. Lift off the Cover Plate and Bracket
3. Remove the Spring from the top of the Disc.
4. Install a lifting bolt into the drilled and tapped hole in the Disc's center and lift from the Base.

**Note:** The Guide may lift out of the Base with the Disc. If so, do not allow the Guide to fall and become damaged.

7. Remove the Guide from the Base if it did not come out with the Disc.
8. O-Ring Disc Disassembly: The O-Ring seat requires the Lock Screw(s) on the bottom of the disc to be removed by turning counterclockwise so that the O-Ring Retainer and Seat-Ring can be removed.
9. If the Nozzle requires rework or replacement, remove the Nozzle from the Base by unscrewing counterclockwise with the appropriate socket or spanner wrench. This applies to all main valve sizes except the 8" and 10" full bore valves. The latter are disassembled by removing four Nozzle Cap Screws, inserting two eyebolts (5/8 - 11 UNC) 180° apart and pulling the nozzle out.
10. Discard all O-Rings, guide rings and seals (as necessary).

No.	Part
1	Spring
2	Cover Plate O-Ring
3	Guide
4	Guide O-Ring
5	Disc Seal
6	Guide Ring(s)
7	Disc
8	Seat O-Ring
9	O-Ring Retainer
10	Lock Screw
11	Nozzle
12	Nozzle O-Ring
13	Cap (Cover Plate) Screws
14	Cover Plate
15	Base

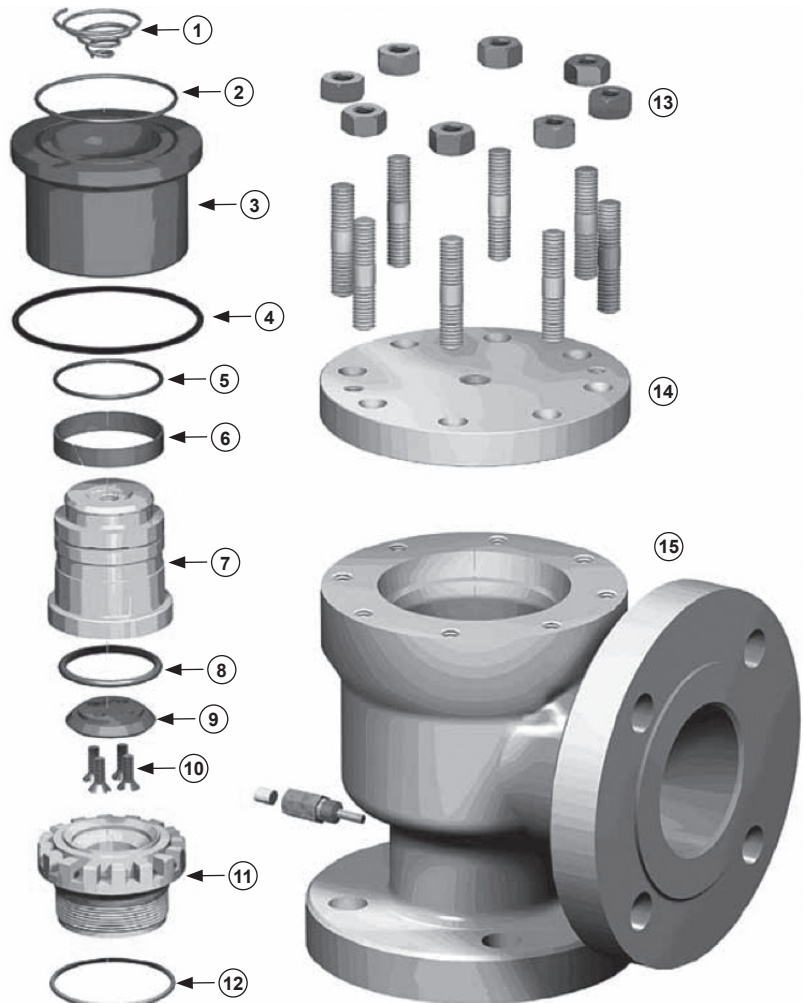
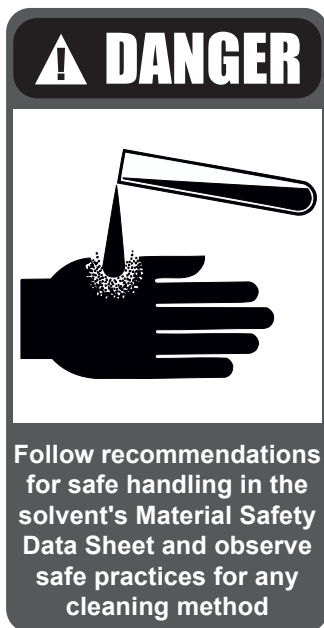

Figure 9

## Cleaning

1. Clean parts to remove all rust, burrs, scale, organic matter and loose particles. Parts are to be free of any oil or grease except for lubrication as specified in this instruction.
2. Cleaning agents used shall be such that effective cleaning is assured without injuring the surface finishes or material properties of the part.
3. Acceptable, cleaning agents include demineralized water, non-phosphate detergent, acetone and isopropyl alcohol. Parts must be blown dry or wiped dry after cleaning.
4. If you are using cleaning solvents, take precautions to protect yourself from potential danger from breathing fumes, chemical burns, or explosion. See the solvent's Material Safety Data Sheet for safe handling recommendations and equipment.
5. Do not "sand blast" internal parts as it can reduce the dimensions.



## Inspection of Main Valve

1. Guide: Check ID for galling or scratch marks, especially around the guide and seal surface areas. Check O-ring/energize seal contact area for any corrosion or scratched surfaces that might cause a leak.

### Replace the guide if:

- a. Visible galling is present on the inside guiding surface.
  - b. Cover Plate O-Ring seating areas are pitted and cause the valve to leak between the cover Plate and Base.
2. Base: Inspect general condition for cracks or holes. Look for any corrosion issues.
  3. Cover Plate: Inspect general condition for cracks or holes. Look for any corrosion issues.
  4. O-Ring Retainer: Inspect surface that sits on the disc for any corrosion on defects that might cause the disc not to sit flush with the nozzle.
  5. Spring: Check for any corrosion issues that might cause the spring not to operate as designed.

6. Nozzle should be replaced if:
  - a. Threads are damaged from pitting and/or corrosion.
  - b. Bottom of the flange and intersecting surface are damaged from galling and/or tearing.
7. O-Ring Seated Disc: The O-Ring Retainer cannot be machined. It can be lapped for minor scratches. If lapping does not fix damaged area, part must be discarded.
8. Disc Holder: Should be replaced if the sliding surface is galled, pitted or scratched.

Replace all parts as needed. If any damage listed above is present, the part should be replaced or repaired per instruction. Other valve parts may be acceptable with light corrosion, pitting or minor damage of other types if it can be determined that it will not affect product performance.

## Reassembly of Main Valve

### A. Lubricants and Sealants

1. Lubricate all O-Rings, spring energized seals, and back-up rings sparingly with silicone grease.
2. Seal all pipe threads with Teflon tape or pipe sealant.
3. Lubricate standard threads and bearing points with Jet-Lube, non-metallic.
4. Disc:
  - a. Remove lapping compound, completely (if applicable).
  - b. Install Disc retainer into the groove in the Disc.
  - c. Lubricate bearing surfaces of Disc, Disc Holder and retainer Ring.
  - d. Snap Disc into Disc Holder using only moderate hand force.
  - e. Check to make sure the Disc does not bind and is free to rock in Disc Holder.

### B. Assembly Procedure for O-Ring Seats

1. Thread Sensing Tube into the Main Valve (rear connection) making sure the wrench flat which reads "Up" is positioned upward after tightening.
2. Thread the tube fitting into the Sensing Tube and tighten
3. Install Nozzle O-Ring over threads of Nozzle and slide until it hits the backside of the flange. Install Nozzle into Base with the appropriate wrench and torque to the value shown in Table 3.
4. Install the Seat Seal O-Ring in the disc groove and positions the O-Ring retainer onto the Disc. Install the Lock Screw(s) and tighten to (245 in-lbs).

### C. Disc to Guide seal

1. For Teflon seals make sure of the integrity of the Teflon seal and seal spring. Install Disc Seal on Disc outside diameter on the opposite end of the disc seat as shown in Figure 9.
2. If an O-Ring seal is used, it is installed in the groove between where the Guide Ring is installed and where a Spring Energized Seal would be installed.

- Install the Guide Ring(s) on Disc outside diameter. If the valve is equipped with two guide rings, position the space where the guide ring ends meet 180° apart.

#### D. Guide and Disc Assembly

- Make sure the chamfer on the Top of the Guide is smooth. If any sharp edges exist, polish the chamfer, since the seal could be damaged during assembly.
- Drop Guide O-Ring into top of Base for outside diameter of Guide.
- Insert Guide into top of Base. It will not fit flush. The Cover Plate will force it down during its installation.
- Insert Disc Assembly into Guide with the Disc seat going in first. Continue pushing disc into Guide, being careful of not pinching the Guide Rings. Push Disc in until the Disc is in contact with the Nozzle.
- Install Cover Plate on top of Base such that the pilot will be aligned for proper tubing connections. Make note of the length of the studs or Cap screws.
- Install Spring into dome cavity with smaller coils on bottom. When installing the Cover Plate, make sure the spring coils remain in the groove and centered.
- Install the Cover Plate on top of Base. Torque bolts to the values found in table 4 using the torque patterns in Figure 10 and table 5.

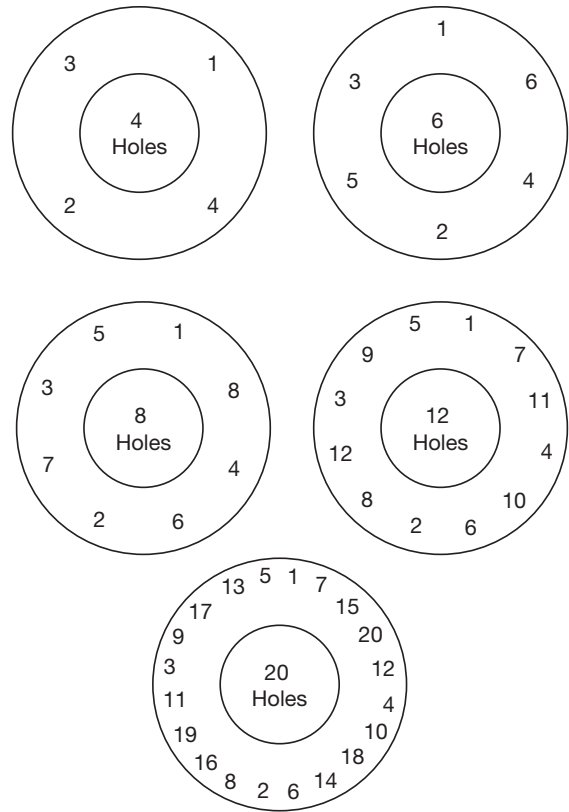

**Figure 10**  
**Bolt Tightening Patterns**

Nozzle Torque Values			
Valve Inlet Size		Nozzle Installation Torque	
in.	mm	ft-lbs ± 5%	N-m ± 5%
1.00	25.4	100	136
1.50	38.1	100	136
2.00	50.8	160	217
3.00	76.2	475	644
4.00	101.6	1070	1451
6.00	152.4	1445	1959
8.00	203.2	1865	2529
Bolted Nozzles		60	81

**Table 3**

Coverplate Cap Screw / Nut Torque						
Inlet Size		Orifice	150CL		300CL	
in.	mm		ft-lb	N-m	ft-lb	N-m
1.50	38.1	Full Bore	120	163	120	163
2.00	50.8	Full Bore	210	285	210	285
3.00	76.2	Full Bore	340	461	340	461
4.00	101.6	Full Bore	340	461	340	461
6.00	152.4	Full Bore	510	691	510	691
8.00	203.2	Full Bore	720	976	720	976
10.00	254.0	Full Bore	720	976	720	976
12.00	304.8	Full Bore	720	976	720	976

**Table 4**

Torque Required for Each Round of Pattern	
Round	Percentage of Required Torque
1	Wrench Tight
2	25
3	60
4	100
5	100

**Table 5**



## General Description

(Figure 11)

①

**Spring Housing:** The Pilot Spring Housing is provided with a 1/4 inch NPT vent connection which may be piped to a safe area or pressure loaded for remote control of the pressure setting. The Main Spring may be changed by simply removing the Closing Cap (1A).

②

**Body Insert Assembly:** A removable Body Insert Assembly (cartridge), at the bottom of the Pilot Body, contains the inner valve mechanism. The cartridge may be replaced with a spare unit for fast trouble shooting or repair. The Body Insert Assembly is also field repairable.

③

**Inlet and Loading Ports:** The INLET port is common with the LOADING port through an internal passage in the pilot. A Restrictor must always be connected to the INLET port when used with the Consolidated main valve. The LOADING port is used to connect and mount the pilot to the dome chamber of the main valve.

④

**Sensing Port:** The SENSE connection is “static” which means that there is no flow in the sensing line and the true pipeline pressure is measured at the diaphragm.

⑤

**Outlet Port:** The OUTLET port must be connected to the valve outlet or outlet pressure system. The Series 20 Pilot has separate SENSE and OUTLET connections. Separate SENSE and OUTLET ports make piping easier.

⑥

**Diaphragm Spacer Assembly:** The addition of this assembly converts the Series 20 & 20S Pilot into the high pressure Series 20H & 20HS. It reduces the pilot diaphragm area and increases the spring range of the black and green springs.

**WARNING:** The pilot is designed for use with an external restrictor (Principle of Operation Section). The restrictor must be the Mooney Type 25 Restrictor and must be installed in the pilot inlet connection (3).

## Reassembly of Pilot to Main Valve

To replace, put Teflon thread tape on NPT nipple end and turn pilot clockwise with nipple in connecting port until snug and oriented properly. Reconnect all tubing - Refer to Figure 6 and Figure 7 for orientation and tubing locations.

## Mooney Series 20 Pilot

### Product Description

The Series 20 Pilot is an independent pneumatically operated flowing auxiliary relief valve intended for controlling the Consolidated\* main valve.

**Series 20** - Brass construction with 15 to 450 psi (0.20 bar - 31.02 bar) control pressure range.

**Series 20H** - High pressure brass construction with a 200 to 750 psi (13.79 bar - 62.05 bar) control pressure range.

**Series 20S** - Stainless steel construction with a 15 to 450 (0.20 bar - 31.02 bar) control pressure range.

**Series 20HS** - High pressure, stainless steel construction with a 200 to 750 psi (13.79 bar - 62.05 bar) control pressure range.

The parts in all constructions are interchangeable. The high pressure construction (Series 20H and 20HS) varies from the Series 20 and 20S with the addition of a diaphragm spacer assembly that reduces the effective area of the diaphragm and increases the spring range of the black and green springs.

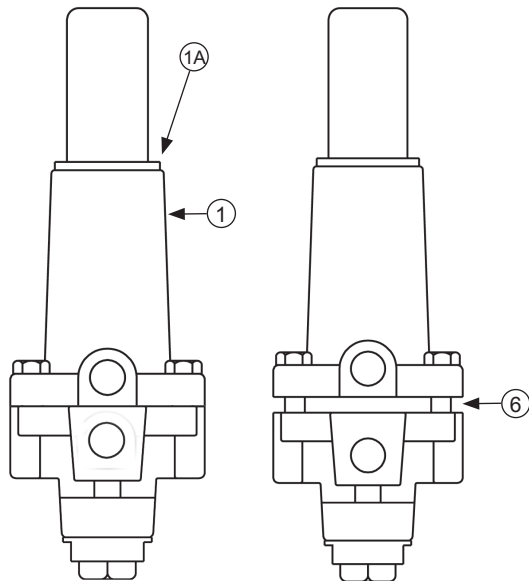

Series 20 & 20S

Series 20H & 20HS

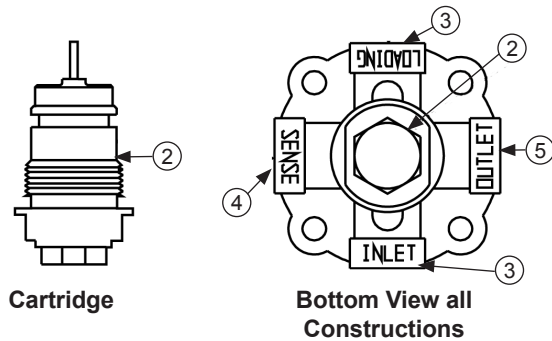

Cartridge

Bottom View all Constructions

Figure 11  
Mooney Series 20 Pilots

**Materials of Construction  
Series 20H & 20HS**

<b>Body &amp; Spring Housing</b>	Forged Brass or 303 Stainless Steel
<b>Body Insert &amp; Closing Cap</b>	Brass or 300 Stainless Steel
<b>Diaphragm Spacer Assembly (20H, 20HS)</b>	300 Stainless Steel
<b>Orifice</b>	300 Stainless Steel or Delrin <sup>(1)</sup>
<b>Plug &amp; Stem</b>	Nitrile/300 Stainless Steel Viton/300 Stainless Steel 300 Stainless Steel
<b>Diaphragm</b>	Nitrile/Nylon or Viton/Nylon
<b>O-Rings</b>	Nitrile or Viton

<sup>(1)</sup> Delrin Orifice with all Stainless Steel Plug/Stem is recommended for all set pressures 100 psi and above (Figure 26).

Table 6

**Specifications  
All Series 20 Pilots**

<b>Control Application</b>	Back Pressure (BPV)
<b>Orifice Size</b>	0.15 in (3.81 mm)
<b>Connections</b>	1/4 in NPT
<b>Temperature</b>	Working -20°F to 150°F (-6.7 °C to 65.7°C) Emergency -40°F to 200°F (-40° C to 93. 3° C)
<b>Maximum Inlet Pressure</b>	750 psig (103.4 bar)
<b>Maximum Loading Pressure</b>	750 psig (103.4 bar)
<b>Maximum Outlet Pressure</b>	750 psig (103.4 bar)
<b>Maximum Emergency Sensing Pressure</b>	1000 psig (68.9 bar)
<b>Maximum Spring Housing Pressure</b>	1000 psig (68.9 bar)
<b>Set Pressure Range</b>	15-750 psig (0.2 - 62.1bar) <sup>(2)</sup>

<sup>(2)</sup> Refer to Table 8 for specific spring ranges.

Table 7

Specifications			
Series	Spring Range	Color	Part Number
20 & 20S	10 - 40 psi (0.7 - 2.7 bar)	Plated	040-011-01
	25 - 90 psi (1.7 - 6.2 bar)	Blue	040-012-01
	60 - 200 psi (4 - 14 bar)	Purple	040-008-01
	100 - 260 psi (7 - 18 bar)	Black	040-009-01
	200 - 450 psi (14 - 31 bar)	Green	040-020-01
20H & 20HS	200 - 520 psi (14 - 36 bar)	Black <sup>(3)</sup>	040-009-01
	400 - 900 psi (27 - 62 bar)	Green <sup>(3)</sup>	040-020-01

<sup>(3)</sup> Spacer on Adjustment Screw Required

Table 8



# Pilot Markings

(Figure 12)

- ① Location of the Pilot nameplate.
- ② Location of spring range nameplate. The factory marks the nameplate to indicate which spring is installed at manufacture date. If the spring is changed, note the new spring on the nameplate.
- ③ The month and year of manufacture is noted on the Spring Case, Body, and Body Insert of the pilot.

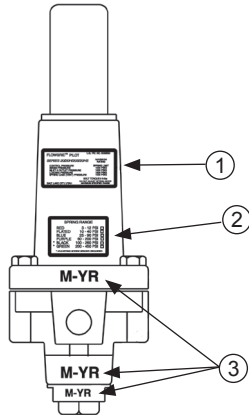

Figure 12

Item	Definition
<b>Mooney Pilot</b>	Trademarked name of pilot.
<b>Series</b>	Model number of pilot.
<b>Control Pressure</b>	The control pressure is limited to the spring range of the spring on the pilot (Refer to Fig. 4 for Series 20 & 20S pilots)
<b>Sense Pressure</b>	Maximum allowable pressure in sense
<b>Inlet &amp; Outlet Pressure</b>	Maximum allowable pressure (psig) to the Inlet and Outlet ports.
<b>Loading Pressure</b>	Maximum allowable pressure (psig) to the Loading port.
<b>Spring Case (Vent) Pressure</b>	Maximum allowable pressure (psig) to the Spring Case (Vent) port.
<b>Bolt Torque</b>	Recommended bolt torque for spring case in foot pounds.
<b>Red, Plated, Blue, Purple, Black and Green</b>	Each spring is color coded to indicate the control pressure range
<b>Adjusting Screw Spacer</b>	The black and green springs require a spacer on the adjusting screw to avoid over compression.

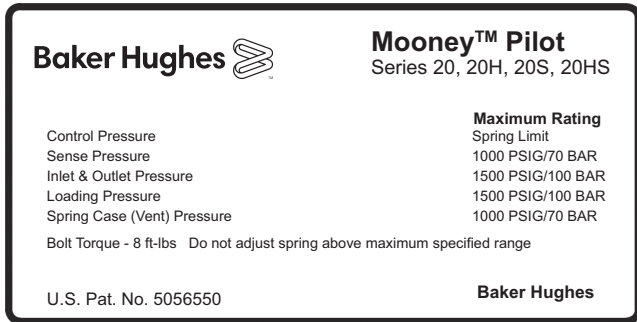

Figure 13

Nameplate for Series 20, 20H, 20S, & 20HS Mooney Pilots

Table 9

SPRING RANGE	
RED	3-12 PSI / 0.2-0.8 BAR <input type="checkbox"/>
PLATED	10-40 PSI / 0.7-2.7 BAR <input type="checkbox"/>
BLUE	25-90 PSI / 1.7-6.2 BAR <input type="checkbox"/>
PURPLE	60-200 PSI / 4-14 BAR <input type="checkbox"/>
+ BLACK	100-260 PSI / 7-18 BAR <input type="checkbox"/>
+ GREEN	200-450 PSI / 14-31 BAR <input type="checkbox"/>

\* ADJUSTING SCREW SPACER REQUIRED

Figure 14

Spring Range Nameplate for Series 20 & 20S Mooney Pilots

HIGH PRESSURE SPRING RANGE	
BLACK	200-520 PSI / 14-36 BAR <input type="checkbox"/>
GREEN	400-900 PSI / 27-62 BAR <input type="checkbox"/>

ADJUSTING SCREW SPACER REQUIRED

Figure 15

Spring Range Nameplate for Series 20H & 20HS Mooney Pilots

# Maintenance

Pilot parts are subject to normal wear and must be inspected and replaced as necessary. The frequency of inspection and replacement of parts depends on severity of service conditions and/or the requirements of local, state, and federal regulations. Be certain that the name plates are updated to accurately indicate any field changes in equipment, materials, service conditions, or pressure settings.

**WARNING: Before disassembly make sure the regulator and pilot have been isolated from the process by closing block valves on the inlet and outlet sides of the regulator. Safely release pressure and process fluid from the regulator body and pilot system. Failure to properly complete these steps may result in personal injury and property damage.**

# Pilot Disassembly

(Figure 16 from pilot IOM)

1. After depressurizing the pilot and main valve unscrew and remove Body Insert Assembly.
2. Remove the Stem O-ring from the pilot body using a suitable tool and being careful not to scratch the O-ring Groove.

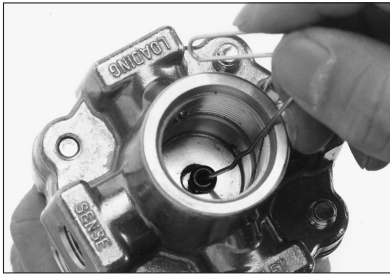

**Figure 16**

A paper clip easily extracts the O-Ring out of the pilot body.

**Note:** A spare Body Insert Assembly may be installed and the main valve returned to service if time is a factor. Make sure the Stem O-Ring is in place in the Pilot Body before installing the new Body Insert Assembly or, if removed, slip a new O-Ring over the Stem of the Body Insert Assembly prior to installing it in the Pilot Body.

3. Remove the Bottom Cap from the Body Insert and remove the internal parts. The Orifice Assembly can be easily pushed out of the Insert Body by pushing on the stem coming out at the top of the Insert Body.

**ATTENTION:** Do not scratch or damage the O-Ring sealing surfaces of the Body Insert.

4. Inspect all parts for wear or damage. Replace as necessary.
5. Pilot Diaphragm: Release all Main Spring tension by unscrewing Adjusting Screw. Remove Closing Cap, Spring Follower, and Main Spring.
6. Remove Spring Housing Cap Screws and remove Diaphragm Assembly.
7. Disassemble Diaphragm Assembly and inspect Diaphragm. Replace if necessary.

# Pilot Assembly

1. Diaphragm Assembly: Install the Pilot Diaphragm with convex side toward Diaphragm Plate and Main Spring (Figure 16). Tighten nut on the Diaphragm Retainer to approximately 5 to 6 ft-lbs (6.78 - 8.14 n-m) torque.

**ATTENTION:** Overtightening will distort the Pilot Diaphragm.

**Note:** The high pressure constructions (Series 20H & 20HS) differ from the Series 20 & 20S with the addition of a diaphragm spacer assembly.

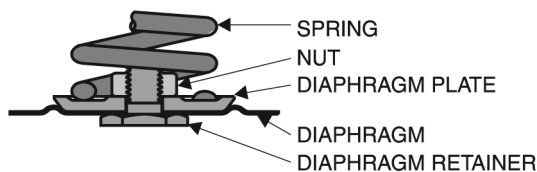

**Figure 17**

**Diaphragm Assembly for the Flowgrid Series 20 & 20S Pilot.**

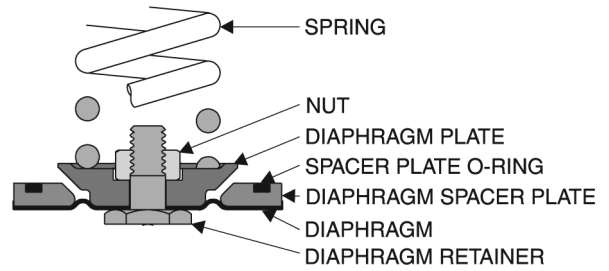

**Figure 18**

**Insert Body Insert (Cartridge) with lubricated Stem O-Ring into the Pilot Body.**

2. Place Diaphragm Assembly in the pilot body with the diaphragm touching the grooved sealing surface of the pilot body. (Figure 13)

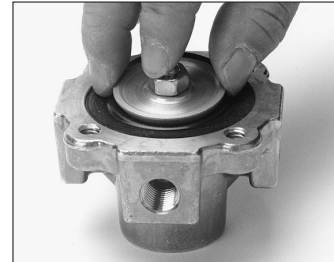

**Figure 19**

**Placing Diaphragm Assembly on Pilot Body.**

3. Place Spring Housing on Pilot Body with the vent port aligned with the loading port so that it will face down when the pilot is mounted on the regulator so that condensation will drain away instead of accumulating and possibly freezing.



**Figure 20**

**Placing the Spring Housing on the Pilot Body.**

4. Install Spring Housing Cap Screws. Use cap screws supplied and tighten evenly to 10 ft-lbs (13.56 n-m) torque.
5. Install Spring and Spring Follower. Lubricate Spring Follower with a Petroleum Oil Grease such as Lubriplate No. 1051.

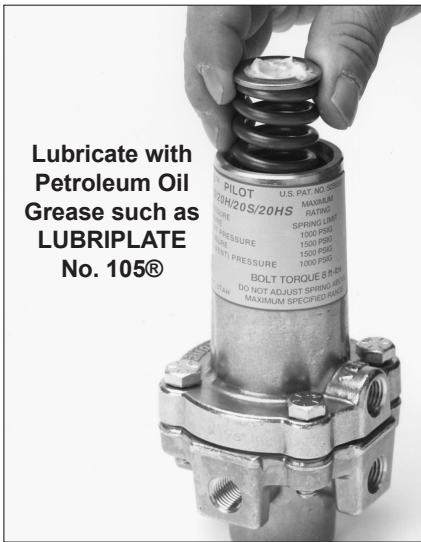

**Figure 21**

**Installing the Spring with lubricated Spring Follower**

- PILOTS WITH PLATED, BLUE, AND PURPLE SPRINGS: Install Closing Cap with Adjusting Screw and Sealing Nut and O-Ring.



**Figure 22**

**Installing the closing cap assembly for Pilot with the Red, Plated, Blue, and Purple Springs**

- PILOTS WITH BLACK AND GREEN SPRING: Install Closing Cap with Adjusting Screw, Spacer, Sealing Nut, and O-Ring. The spacer prevents the Black and Green springs from being over compressed.



**Figure 23**

**Installing the closing cap assembly with spacer (to prevent spring over compression) for Pilots with the Black and Green Springs.**



**Figure 24**

**The Plug and Stem Assembly**

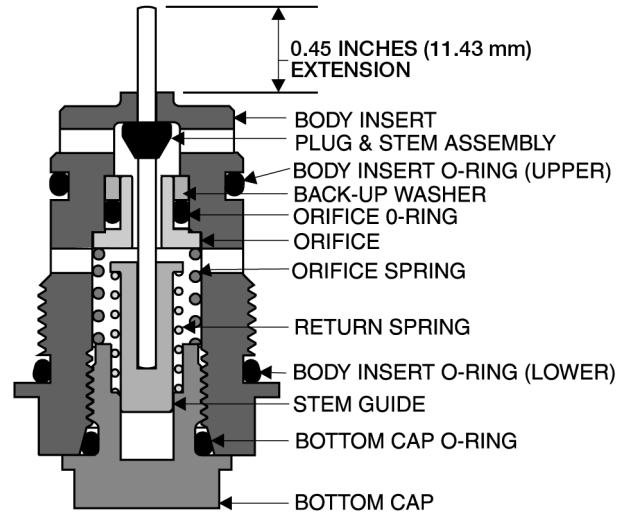
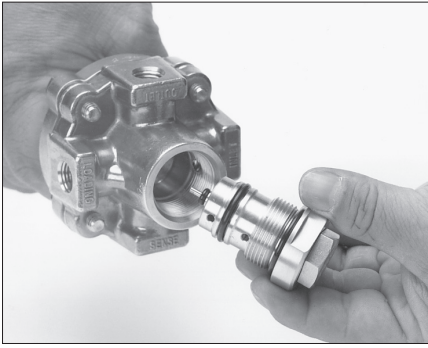

**Figure 25**

- Refer to Figure 22 & 23. Stack the following parts on the Bottom Cap in the order shown in the drawing: Return Spring, Stem Guide, Orifice Spring, Orifice, Orifice O-Ring, Back-Up Washer, Plug and Stem

**NOTE: The plug on the stem will be ABOVE the Orifice Assembly for Relief (BPV) Mode.**

- Lubricate both Body Insert O-Rings with Parker O-Lube® (or equivalent Petroleum based Lubricant) and install on Body Insert (Cartridge).
- Body Insert Assembly: Lift Bottom Cap complete with valve mechanism assembly and insert into Body Insert. The Orifice Spring should snap the Orifice into place as the Bottom Cap is screwed into place. Check the assembly by pushing the Stem against a hard surface to make sure it moves freely and returns to the extended position.
- Measure the Stem Extension: should be .45" (11.43mm)
- Lubricate Stem O-Ring with Parker Super-O-Lube® (or equivalent Silicon Lubricant) and slip over Stem.
- Insert Body Insert into Pilot Body and screw into place snugly.



**Figure 26**

**Insert Body Insert (Cartridge) with Lubricated Stem O-Ring into the Pilot Body**

**ATTENTION:** Over tightening an O-Ring Joint will not improve the seal. Screw in until metal parts make contact and snug slightly.

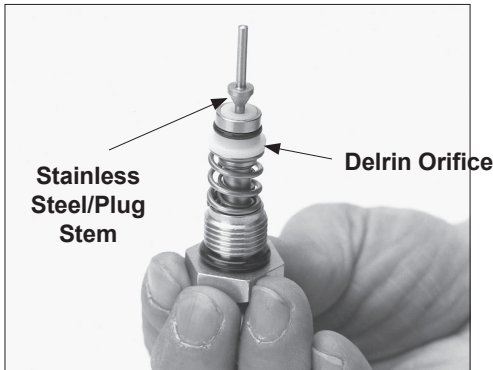

**Figure 27**

**Delrin Orifice and Stainless Steel Plug/Stem assembly in the Back Pressure mode. The white Delrin material distinguishes itself from the standard stainless steel orifice**

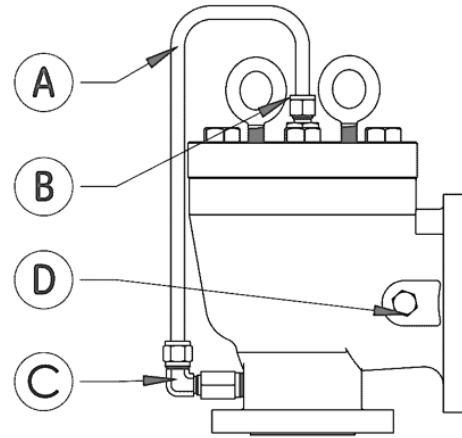

**Figure 28**

## Accessories

### Manual or Remote Blowdown Valve

Blowdown valves allow bleeding of the dome pressure manually by hand (ball valve) or by electronic signal (solenoid). This action overrides the pilot until the blowdown valve is closed again. The pilot then regains control of the system and responds according to system conditions.

### Pressure Differential Switch

A pressure differential switch is available which may be wired to an operator station or some other remote location. The switch will provide a signal that indicates when the main valve is opening.

## Hydrostatic Testing

All Mooney Series 20 Relief Valves are hydrostatically tested prior to shipment according to ISA-S75.19.01-2013. If it is necessary to retest the valve, use the following procedure:

1. Disconnect and remove all control line(s) and the pilot from the main valve.
2. Tube (A) the inlet neck NPT port (C) with the dome NPT port (B) so that they are common. (Figure 28)
3. Plug the outlet NPT port (D).
4. Increase pressure slowly so the pressure has a chance to stay equalized in both the inlet and dome chambers. (Smallest restriction is about 3/16" DIA.)
5. Maximum valve hydrostatic pressure for each class:
  - a. 150CL: 450 psi
  - b. 300CL: 1125 psi
6. After hydrostatic test is completed, follow the disassembly, cleaning, and assembly procedures in the respective Maintenance Manuals.

**WARNING: Maximum Valve Hydrostatic Pressure is not the same as Line Hydrostatic Pressure**

**All the USCS values are converted to  
metric values using the following conversion factors:**

<b>Metric values using the following conversion factors:</b>	<b>Conversion Factor</b>	<b>Metric Unit</b>
in.	25.4	mm
lb.	0.4535924	kg
in <sup>2</sup>	6.4516	cm <sup>2</sup>
ft <sup>3</sup> /min	0.02831685	m <sup>3</sup> /min
gal/min	3.785412	L/min
lb/hr	0.4535924	kg/hr
psig	0.06894757	barg
ft lb	1.3558181	Nm
°F	5/9 (°F-32)	°C

**Note: Multiply USCS value with conversion factor to get metric value.**

# Notes

## Notes

# Direct Sales Office Locations

**Australia**

Brisbane  
Phone: +61-7-3001-4319

Perth  
Phone: +61-8-6595-7018

Melbourne  
Phone: +61-3-8807-6002

**Brazil**

Phone: +55-19-2104-6900

**China**

Phone: +86-10-5738-8888

**France**

Courbevoie  
Phone: +33-1-4904-9000

**India**

Mumbai  
Phone: +91-22-8354790

New Delhi

Phone: +91-11-2-6164175

**Italy**

Phone: +39-081-7892-111

**Japan**

Tokyo  
Phone: +81-03-6871-9008

**Korea**

Phone: +82-2-2274-0748

**Malaysia**

Phone: +60-3-2161-03228

**Mexico**

Phone: +52-55-3640-5060

**Russia**

Veliky Novgorod  
Phone: +7-8162-55-7898

Moscow

Phone: +7-495-585-1276

**Saudi Arabia**

Phone: +966-3-341-0278

**Singapore**

Phone: +65-6861-6100

**South Africa**

Phone: +27-11-452-1550

**South & Central  
America and the Caribbean**

Phone: +55-12-2134-1201

**Spain**

Phone: +34-935-877-605

**United Arab Emirates**

Phone: +971-4-8991-777

**United Kingdom**

Phone: +44-7919-382-156

**United States**

Houston, Texas  
Phone: +1-713-966-3600

**Find the nearest local Channel Partner in your area:**

[valves.bakerhughes.com/contact-us](http://valves.bakerhughes.com/contact-us)

## Tech Field Support & Warranty:

Phone: +1-866-827-5378

[valvesupport@bakerhughes.com](mailto:valvesupport@bakerhughes.com)

[valves.bakerhughes.com](http://valves.bakerhughes.com)

Copyright 2021 Baker Hughes Company. All rights reserved. Baker Hughes provides this information on an "as is" basis for general information purposes. Baker Hughes does not make any representation as to the accuracy or completeness of the information and makes no warranties of any kind, specific, implied or oral, to the fullest extent permissible by law, including those of merchantability and fitness for a particular purpose or use. Baker Hughes hereby disclaims any and all liability for any direct, indirect, consequential or special damages, claims for lost profits, or third party claims arising from the use of the information, whether a claim is asserted in contract, tort, or otherwise. Baker Hughes reserves the right to make changes in specifications and features shown herein, or discontinue the product described at any time without notice or obligation. Contact your Baker Hughes representative for the most current information. The Baker Hughes logo and Mooney are trademarks of Baker Hughes Company. Other company names and product names used in this document are the registered trademarks or trademarks of their respective owners.

**Baker Hughes** 