

Masoneilan\*

# SVi\* 1000 Positioner

Quick Start Guide (Rev. L)

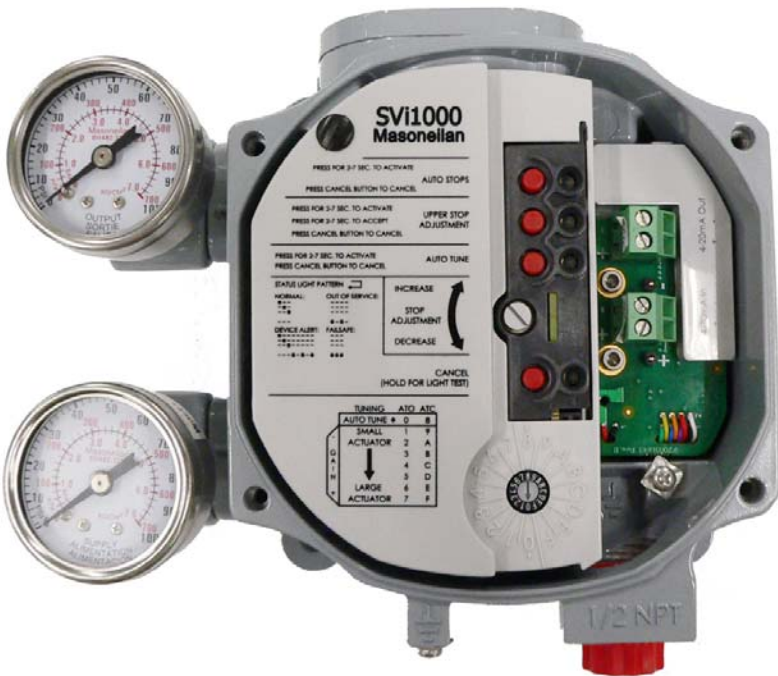

## About this Guide

This Quick Start Guide applies to the SVi1000 instrument and supported software:

- with firmware version 2.2.1 (for use with HART® 5) or 3.1.1 (for use with HART® 7).
- with ValVue 3 version 3.20.0 or greater
- with a HART® Communicator with DD published for SVi1000

All information contained herein is believed to be accurate at the time of publication and is subject to change without notice.

The information contained in this manual, in whole or part, shall not be transcribed or copied without BHGE's written permission.

In no case does this manual guarantee the merchantability of the positioner or the software or its adaptability to a specific client needs.

Please report any errors or questions about the information in this manual to your local supplier or visit [valves.bhge.com](http://valves.bhge.com).

## DISCLAIMER

THESE INSTRUCTIONS PROVIDE THE CUSTOMER/OPERATOR WITH IMPORTANT PROJECT-SPECIFIC REFERENCE INFORMATION IN ADDITION TO THE CUSTOMER/OPERATOR'S NORMAL OPERATION AND MAINTENANCE PROCEDURES. SINCE OPERATION AND MAINTENANCE PHILOSOPHIES VARY, BHGE (BAKER HUGHES, A GE COMPANY LLC AND ITS SUBSIDIARIES AND AFFILIATES) DOES NOT ATTEMPT TO DICTATE SPECIFIC PROCEDURES, BUT TO PROVIDE BASIC LIMITATIONS AND REQUIREMENTS CREATED BY THE TYPE OF EQUIPMENT PROVIDED.

THESE INSTRUCTIONS ASSUME THAT OPERATORS ALREADY HAVE A GENERAL UNDERSTANDING OF THE REQUIREMENTS FOR SAFE OPERATION OF MECHANICAL AND ELECTRICAL EQUIPMENT IN POTENTIALLY HAZARDOUS ENVIRONMENTS. THEREFORE, THESE INSTRUCTIONS SHOULD BE INTERPRETED AND APPLIED IN CONJUNCTION WITH THE SAFETY RULES AND REGULATIONS APPLICABLE AT THE SITE AND THE PARTICULAR REQUIREMENTS FOR OPERATION OF OTHER EQUIPMENT AT THE SITE.

THESE INSTRUCTIONS DO NOT PURPORT TO COVER ALL DETAILS OR VARIATIONS IN EQUIPMENT NOR TO PROVIDE FOR EVERY POSSIBLE CONTINGENCY TO BE MET IN CONNECTION WITH INSTALLATION, OPERATION OR MAINTENANCE. SHOULD FURTHER INFORMATION BE DESIRED OR SHOULD PARTICULAR PROBLEMS ARISE WHICH ARE NOT COVERED SUFFICIENTLY FOR THE CUSTOMER/OPERATOR'S PURPOSES THE MATTER SHOULD BE REFERRED TO BHGE.

THE RIGHTS, OBLIGATIONS AND LIABILITIES OF BHGE AND THE CUSTOMER/OPERATOR ARE STRICTLY LIMITED TO THOSE EXPRESSLY PROVIDED IN THE CONTRACT RELATING TO THE SUPPLY OF THE EQUIPMENT. NO ADDITIONAL REPRESENTATIONS OR WARRANTIES BY BHGE REGARDING THE EQUIPMENT OR ITS USE ARE GIVEN OR IMPLIED BY THE ISSUE OF THESE INSTRUCTIONS.

THESE INSTRUCTIONS ARE FURNISHED TO THE CUSTOMER/OPERATOR SOLELY TO ASSIST IN THE INSTALLATION, TESTING, OPERATION, AND/OR MAINTENANCE OF THE EQUIPMENT DESCRIBED. THIS DOCUMENT SHALL NOT BE REPRODUCED IN WHOLE OR IN PART TO ANY THIRD PARTY WITHOUT THE WRITTEN APPROVAL OF BHGE.

## Copyright

Copyright 2019 by Baker Hughes, a GE company LLC. All rights reserved.

PN 720008664-779-0000 REV L.

# Contents

<b>1. Safety Information</b> .....	<b>5</b>
Documentation Symbols.....	5
SVi1000 Product Safety.....	6
Masoneilan Help Contacts.....	7
<b>2. Introduction</b> .....	<b>9</b>
Introduction.....	9
Functionality.....	10
Modes.....	13
LED Light Functions.....	15
Major Components.....	17
<b>3. Mounting and Wiring</b> .....	<b>19</b>
Introduction.....	19
Step 1: Mounting the SVi1000.....	21
Necessary Precautions .....	21
Mounting the SVi1000 on Rotary Valves .....	22
Mounting the SVi1000 on Reciprocating Valves .....	27
Integrated Magnet Assembly .....	30
Step 2: Connecting the Tubing and Air Supply.....	31
Step 3: Wiring the SVi1000 .....	32
Wiring Guidelines .....	33
Wiring an SVi1000 Unit .....	34
<b>4. Check Out and Configuration</b> .....	<b>39</b>
Overview .....	39
Step 1: Inspect the Actuator, Linkages, or Rotary Adapter .....	41
Step 2: Verify Mounting and Linkage Adjustment .....	41
Step 3: Checking the Magnet .....	41
Perform a Visual Inspection .....	41
Use ValVue to Check Magnet Position .....	42
Step 4: Checking the Air Supply.....	42
Step 5: Verify Wiring Connections.....	43
Step 6: Configuration.....	43
Auto Find Stops .....	43
Open Stops Adjustments .....	44
Tuning .....	45
Auto Tune .....	48
<b>5. ValVue Software and the SVi1000</b> .....	<b>49</b>
ValVue Overview .....	49
ValVue and SVi1000 DTM Trial Version .....	49
ValVue and SVi1000 DTM Software Installation .....	50
Masoneilan Software .....	50

HART® Handheld Communicator .....	55
<b>A. SVi1000 Theory .....</b>	<b>57</b>
Introduction .....	57
SVi1000 Setups .....	57
Grounding Practices .....	58
Compliance Voltage in Single Drop Current Mode .....	58
<b>B. Optional Switch Load Limits .....</b>	<b>59</b>
General Configuration Notes.....	59
Optional Retransmit Output.....	62
<b>C. Determining an SVI Positioner Compliance Voltage in a Control System .....</b>	<b>63</b>
Introduction .....	62
Compliance Test Set-Up .....	63
<b>D. Specifications, Spare Parts and References .....</b>	<b>65</b>
Physical and Operational Specifications.....	65
Spare Parts.....	71
Hazardous Location Installation and Declaration of Conformity.....	72

## Document Changes

Version/Date	Changes
B/01-2012	Updated ES-761 to Rev. B.
C/04-2012	Updated ES-761 to Rev. D.
D/05-2013	Updated Rotary Kit Components.all.
E/09-2013	Updated load limits switch drawing and added a reference to that section in installation. Added polarity caution to the Load Limits section. Inserted ES-761 Rev. E.
F/03-2016	Updated load limits section. Updated wiring and general descriptions to include retransmit wiring and features. Inserted ES-761 Rev. F. Updated all references to ValVue to reflect on ValVue version 3, along with licensing changes.
G/03-2017	Add section on Determining Compliance Voltage. Updated Load Limits section for Flyback diode. Updated software download sections. Updated ES to rev. G.
H/12-2017	Updated Load Limits section.
J/01-2018	Updated Load Limits section. Skipped K.
L/06-2019	Updated software installation section. Added support contact information. Updated graphics in DO switches section. Update ES-761 to Rev H.

# 1. Safety Information

This section provides safety information and defines the documentation symbols.

## Documentation Symbols

SVi1000 instructions contain warnings, cautions and notes, where necessary, to alert you to safety related or other important information. Read the instructions carefully before installing and maintaining your instrument. Total compliance with all **WARNING**, and **CAUTION** notices is required for safe operation.

**WARNING**



*Indicates a potentially hazardous situation, which if not avoided could result in serious injury or death.*

**CAUTION**



*Indicates a potentially hazardous situation, which if not avoided could result in instrument or property damage, or data loss.*

**NOTE**



*Indicates important facts and conditions.*

# SVi1000 Product Safety

For SVi1000 positioners intended for use with industrial compressed air:

Ensure that an adequate pressure relief provision is installed when the application of system supply pressure could cause peripheral equipment to malfunction. Installation must be in accordance with local and national compressed air and instrumentation codes.

## *General installation, maintenance or replacement*

- Products must be installed in compliance with all local and national codes and standards by qualified personnel using safe site work practices. Personal Protective Equipment (PPE) must be used per safe site work practices.
- Ensure proper use of fall protection when working at heights, per safe site work practices. Use appropriate safety equipment and practices to prevent the dropping of tools or equipment during installation.
- Under normal operation, compressed supply gas is vented from the SVi1000 to the surrounding area, and may require additional precautions or specialized installations.

## *Intrinsically Safe Installation*

Products certified for use in intrinsically safe installations **MUST BE**:

- Installed, put into service, used and maintained in compliance with national and local regulations and in accordance with the recommendations contained in the relevant standards concerning those environments.
- Used only in situations that comply with the certification conditions shown in this document and after verification of their compatibility with the zone of intended use and the permitted maximum ambient temperature.
- Installed, put into service and maintained by qualified and competent professionals who have undergone suitable training for instrumentation used in such areas.

### **WARNING**



*Before using these products with fluids/compressed gases other than air or for non-industrial applications, consult the factory. This product is not intended for use in life support systems.*

### **WARNING**



*Do not use damaged instruments.*

## WARNING



*Installation in poorly ventilated confined areas, with any potential of gases other than oxygen being present, can lead to a risk of personnel asphyxiation.*

Use only genuine replacement parts which are provided by the manufacturer, to guarantee that the products comply with the essential safety requirements of the European Directives.

Changes to specifications, structure, and components used may not lead to the revision of this manual unless such changes affect the function and performance of the product.

## Masoneilan Help Contacts

- Email: [svisupport@bhge.com](mailto:svisupport@bhge.com)
- Phone: 888-SVI-LINE (888-784-5463)

*This page intentionally left blank.*



# 2. Introduction

## Introduction

The SVi1000 Quick Start Guide is intended to help an experienced field technician efficiently install and setup an SVi1000. If you experience problems that are not documented in this guide, refer to the SVi1000 Instruction Manual, call your local representative, go to [valves.bhge.com](http://valves.bhge.com), or contact our helpdesk at (+1) 888-784-5463. Sales offices are listed on the last page of this document.

This section gives an introduction to the positioner and its components.

# Functionality

All connections to electronic module in the unit are made through the interface board. The SVi1000 standard interface board has a terminal block with screw connectors.

Optionally, you can order a unit configured with two digital switches or a 4 - 20 mA position re-transmit output.

Figure 1 shows the standard interface board.

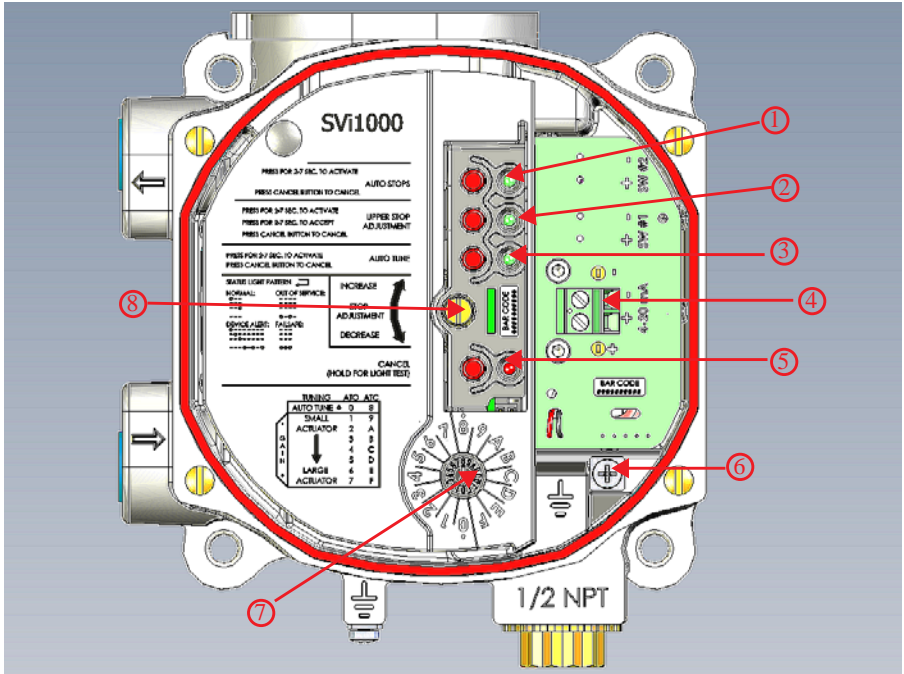

- ① Auto Find Stops Button and LED 1
- ② Upper Stop Button and LED 2
- ③ Auto Tune Button and LED 3
- ④ 4- 20 mA Input Signal
- ⑤ Cancel/ Status Button and LED 4
- ⑥ Ground
- ⑦ Configuration Selection Switch
- ⑧ Open Stop Adjustment Screw

Figure 1 Operator Controls - Standard

Figure 2 shows the optional switch interface board and optional gauges.

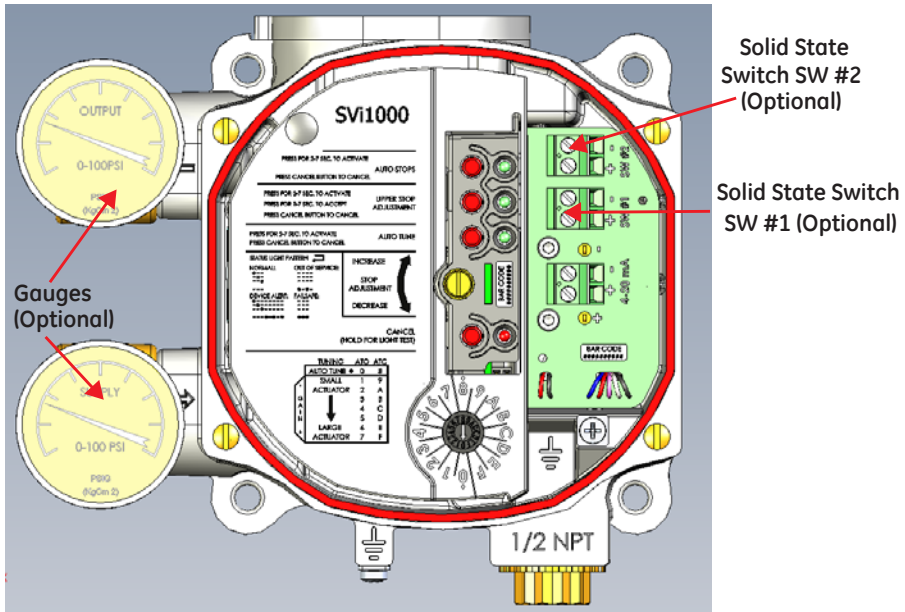

Figure 2 Optional Digital Switches and Gauges

Figure 3 shows the optional position retransmit interface board and optional gauges.

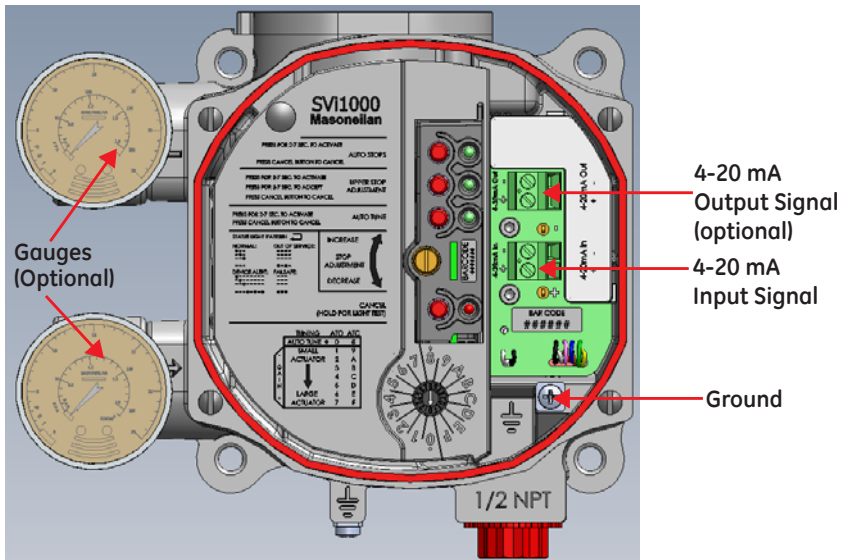

Figure 3 Optional Position Retransmit

The local user interface is where you configure the unit and perform system operations. These operations consists of:

- |                                       |  |
|---------------------------------------|--|
| <i>Configuration Selection Switch</i> | This switch provides control to the following functions: <ul style="list-style-type: none"><li><input type="checkbox"/> Actuator Air Action</li><li><input type="checkbox"/> Select autotuned or preset tuning parameters</li></ul>        |
| <i>Auto Find Stops</i>                | This function automatically sets the lower and upper stops. See “Auto Find Stops” on page 43 for this procedure.   |
| <i>Open Stop Adjustment</i>           | Use the Open Stop Adjustment screw to perform an upper stop adjustment and save it to the device. See “Open Stops Adjustments” on page 44 for this procedure.  |
| <i>Autotuning</i>                     | The autotune process determines optimum tuning parameters for the valve being commissioned. This function is only active when the Configuration Selector Switch is set to <i>AutoTune</i> . See “Auto Tune” on page 48 for this procedure. |

# Modes

The SVi1000 provides the following modes of operation

- Normal mode
- HART® Override mode (ValVue Manual and Setup Modes)
- Failsafe mode
- Commission Process (Via Local User Interface)
  - Find Stops via Local User Interface
  - Manual upper stops adjustment via Local User Interface
  - Autotune via Local User Interface

The SVi1000 always starts up in the mode that the unit was last in before power down, except for failsafe mode when the condition causing fail safe has been corrected.

## WARNING



*Always ensure the SVi1000 has returned to Normal mode after any configuration activity.*

### Normal Mode

In this mode the valve follows the 4-20 mA input signal.

### HART® Override mode

In HART® override mode, the local user interface buttons are disabled until any button is pushed, then local control is reestablished.

This, from the instrument interface, functions as Manual and Setup mode from the optional laptop-based software and other HART® interface tools.

In HART® Override Mode the following tasks are supported over HART® by ValVue or DTM based interface:

- |   |  |
|---|--|
| <input type="checkbox"/> Set Characterization (Linear, Equal%(30,50,Camflex), Quick Open and Custom | <input type="checkbox"/> Enable or Disable Bumpless Transfer                                   |
| <input type="checkbox"/> Set Near Closed Value  | <input type="checkbox"/> Allow Tune to Override limits   |
| <input type="checkbox"/> Configure Tight Shutoff  | <input type="checkbox"/> Set Lower and Upper Position Limits                                   |
| <input type="checkbox"/> Configure Position Fault Limits (Position Error Band and Time 1)           | <input type="checkbox"/> Configure Switch I/O  |
| <input type="checkbox"/> Run Find Stops   | <input type="checkbox"/> Run AutoTune (Provided the option is set at the local user interface) |

- Perform a Manual Find Stops
- Set Open Stop Adjustment
- Set Valve Position
- Command valve to full open or closed

*Failsafe Mode* When a fault results in Failsafe mode being activated, the output pressure of the SVi1000 is set low and the red status LED illuminates continuously. If the fault is considered self-clearing, then once corrected, the unit returns to Normal mode. If the fault is not self-clearing, then the unit requires a reset after correcting the failsafe condition.

*Commission Processes* These are temporary states activated when a local user interface issued command dictates their use. When the positioner is in a Commission Processes a status light indicates this activity (see “LED Light Functions” on page 15). Examples of Commission Processes are Auto Find Stops and Auto Tune. Once a task completes the unit returns to Normal mode.

# LED Light Functions

Figure 4 shows the local user interface LEDs and explains their patterns and timings.

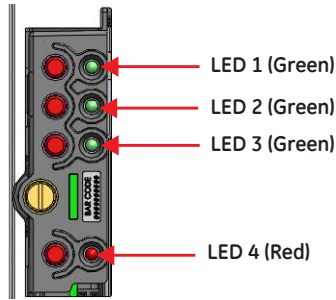

Figure 4 SVI1000 LEDs

In Table 1 dots represent an LED being active and dashes represent the LEDs off. The pattern shown recurs as long as that condition exists.

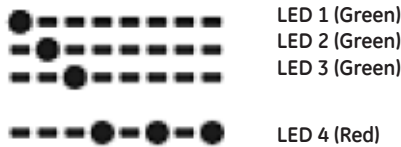



Figure 5 Example LED Pattern

Table 1: LED Light Patterns and Troubleshooting

Indication	Pattern
Normal mode	 LED 1 LED 2 LED 3
Device Alert (Fault mode (self-correcting))	 LED 1 LED 2 LED 3 LED 4
Out of Service (HART® Override mode)	 LED 1 LED 2 LED 3 LED 4

**Table 1: LED Light Patterns and Troubleshooting (Continued)**

Indication	Pattern
Failsafe mode	 <p>LED 1 LED 2 LED 3 LED 4</p>
<b>Troubleshooting</b>	
Device is not powered or in Low Power mode	All LEDs off. Power is not sufficient.
Process Failure	 <p>Pattern depends on which process failed and repeats until Cancel button is pushed.</p>
Setting out of range	If a setting is out of range the associated Green LED flashes at twice the rate as normal until an acceptable range is applied.



# Major Components

Figure 6 shows the unit's major components for reference.

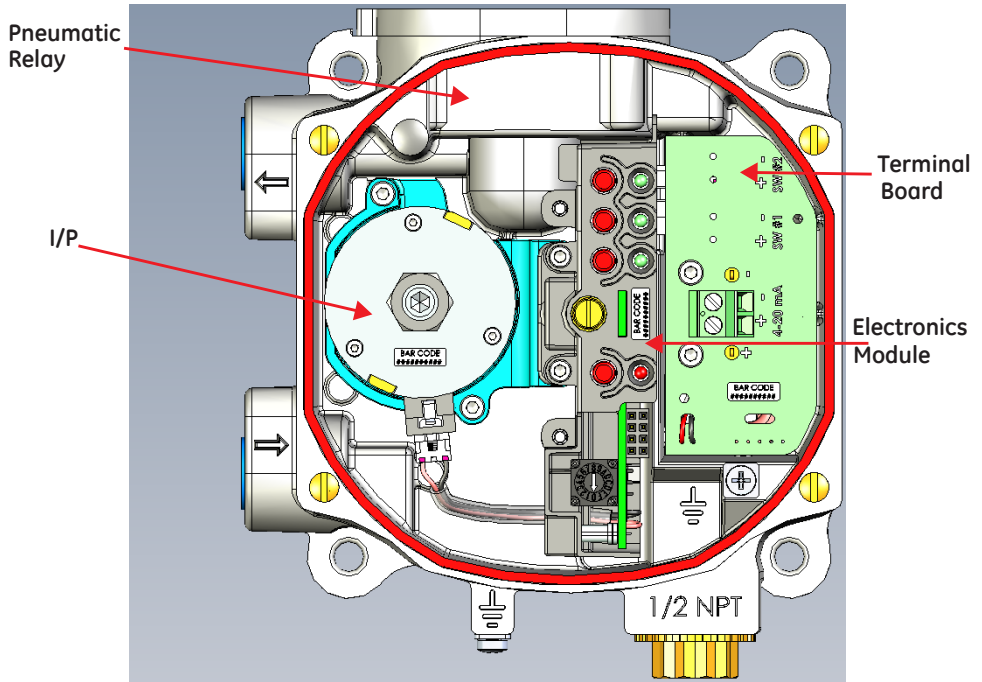

Figure 6 SVi1000 Major Components

*This page intentionally left blank.*

# 3. Mounting and Wiring

## Introduction

This section describes how to mount and wire the SVi1000, which includes:

- “Step 1: Mounting the SVi1000” on page 21.
- “Mounting the SVi1000 on Rotary Valves” on page 22
- “Mounting the SVi1000 on Reciprocating Valves” on page 27
- “Step 2: Connecting the Tubing and Air Supply” on page 31
- “Step 3: Wiring the SVi1000” on page 32

### WARNING



*Failure to adhere to the requirements listed in this manual may cause loss of life and property.*

*Before installing or using this instrument, **READ THE INSTRUCTIONS CAREFULLY.** Refer to “Hazardous Location Installation and Declaration of Conformity” on page 72 for detailed instructions.*

### WARNING



*Do not connect a non-intrinsically safe approved PC or HART<sup>®</sup> modem to an intrinsically safe circuit except on the safe area side of the barrier. Do not operate a PC in a hazardous area without compliance to local and plant regulations. “Hazardous Location Installation and Declaration of Conformity” on page 72*

### CAUTION



*For units with optional switches refer to “Optional Switch Load Limits” on page 59.*

## CAUTION



*Do not connect a HART<sup>®</sup> modem and PC to a control circuit unless the controller is HART<sup>®</sup> compatible or has a HART<sup>®</sup> filter. Loss of control or a process upset may occur if the controller output circuit is not compatible with a HART<sup>®</sup> signal.*

# Step 1: Mounting the SVi1000

This guide provides installation instructions for mounting an SVi1000 on both rotary and reciprocating style valves. The mounting process can be broken down into the following:

1. Attach the mounting bracket to the actuator.
2. Install the magnetic assembly.
3. Assemble the SVi1000 on the mounting bracket.

## CAUTION



*The SVi1000 cover must be in place and secured using all four screws during operation.*

## NOTE



*Mount the SVi1000 with the conduit connection down in order to facilitate drainage of condensate from the conduit.*

## Necessary Precautions

To avoid injury or the process being affected when installing or replacing an SVi1000 positioner on a control valve, ensure that:

- If the valve is located in a hazardous area, ensure the area has been certified as *safe* or that all electrical power to the area has been disconnected before removing any covers or disconnecting any leads.
- Shut off air supply to the actuator and to any valve mounted equipment.
- Ensure the valve is isolated from the process by either shutting off the process or using bypass valves for isolation. Tag shutoff or bypass valves to guard against a *turn-on* while work is in progress.
- Bleed air from actuator and check that valve is in its unenergized position.

For the procedure to install rotary and reciprocating mounting kits on valves, refer to the instructions contained in the valve's mounting box kit.

## Mounting the SVi1000 on Rotary Valves

This section describes the procedure for mounting the SVi1000 on rotary control valves that have less than 60° rotation, such as the Camflex.

Figure 7 shows the kit components.

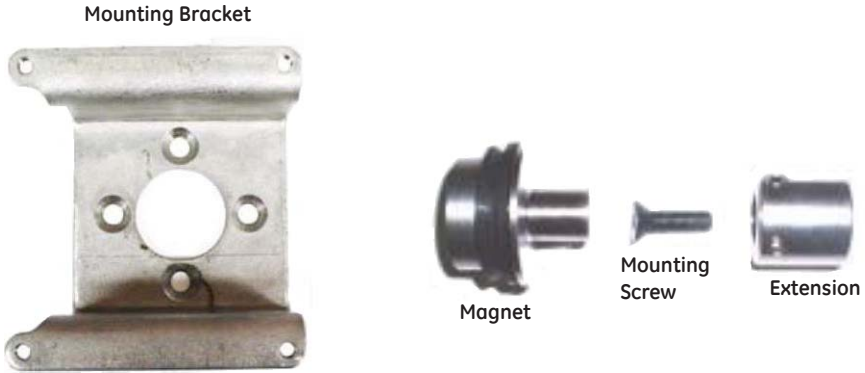

Figure 7 Rotary Kit Components

Figure 8 shows a side view of a Camflex actuator, the SVi1000, and a mounting bracket.

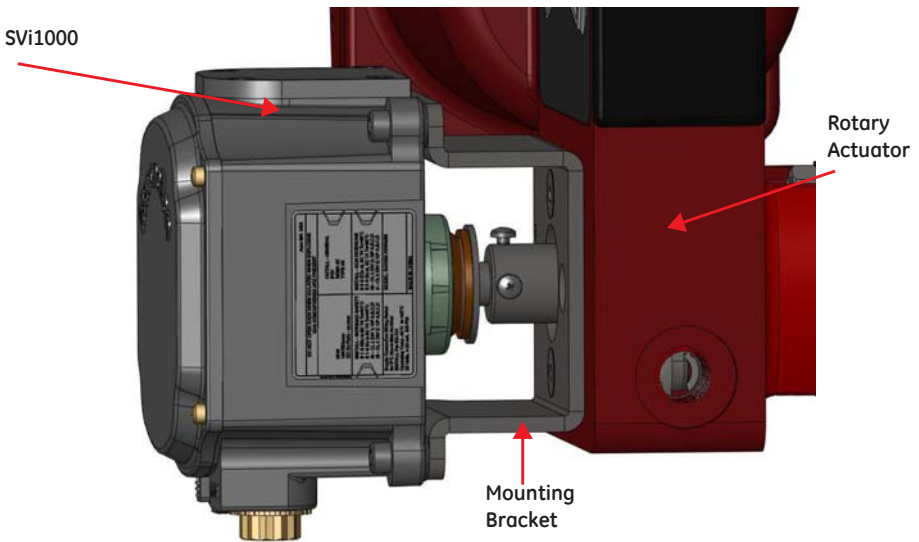

Figure 8 Camflex with Mounting Bracket (Side View)

Tools required:

- M5 Hex Key
- M4 Hex Key
- M3 Hex Key

To mount the SVi1000:

1. Attach the mounting bracket to actuator (Figure 9).

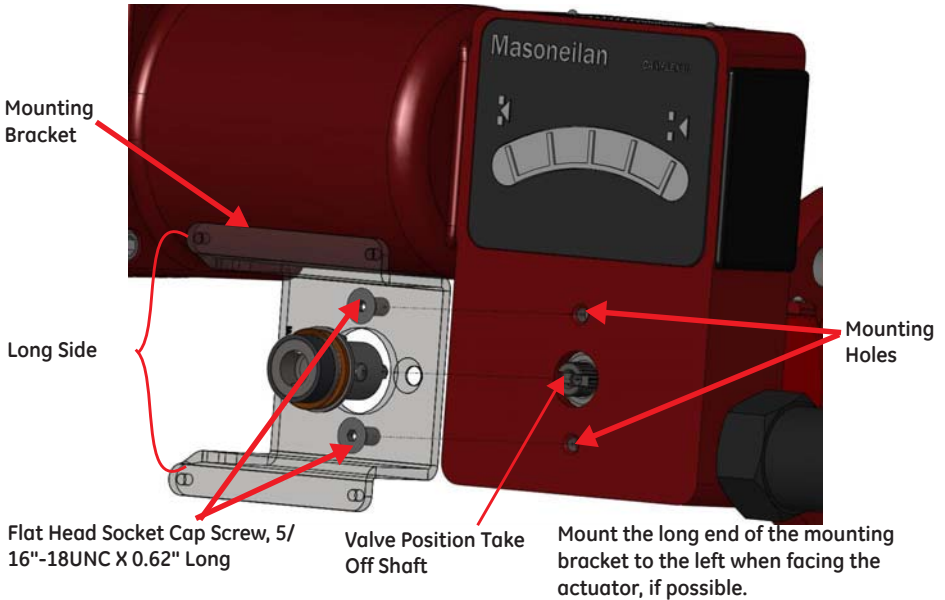

Figure 9 Rotary Mounting Bracket to Valve Actuator

2. Bolt the extension shaft to the valve position take-off shaft (Figure 10).

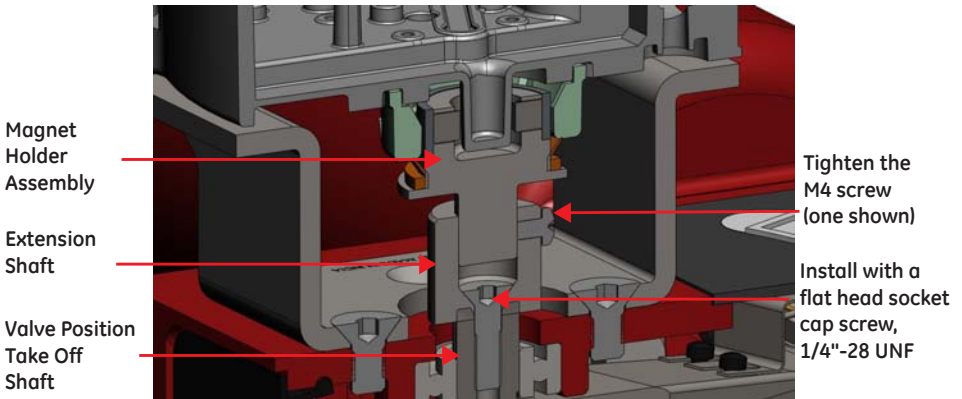





Figure 10 Extension Shaft to the Valve Position Take-off Shaft

Internal valve pressure	The valve plug shaft is pushed out to the mechanical stops, usually a thrust bearing. On valves where the valve position take-off is mounted directly on the end of the plug shaft, a Camflex for example, the shaft must be bearing on its stop to properly set up the SVi1000 positioner. During hydrostatic testing the shaft is thrust to its stop and a normally tightened packing retains it in that position.
Vacuum service	The valve shaft is drawn into the body by the vacuum acting on the shaft, but the magnetic coupling must be assembled flush with the mounting bracket.

3. Perform magnet install and travel sensor alignment by:
  - a. Sliding the magnet holder into the extension shaft. The magnets are in the magnet holder ring. The magnetic axis is the imaginary line through the center of both magnets.
  - b. Rotating the magnet holder so that the magnet axis is vertical when the valve is in the closed position (Table 2). If mounting kit is installed on fail-open valve, apply air to the actuator to close the valve before installing magnet holder.



**Table 2: Travel Sensor Alignment**

Rotary Mounting System	Stroke Direction	Magnet Orientation	Valve Position	Sensor Counts
Rotary	<60° Rotation Clockwise or counter-clockwise rotation	 <p>(0°)</p>	Closed (0%)	0 +/- 1000
	>60° Rotation Clockwise with increasing setpoint	 <p>(-45°)</p>	Full Open or Full Closed	-8000 +/- 1500 or +8000 +/- 1500
	>60° Rotation Counter Clockwise rotation with increasing setpoint	 <p>(+45°)</p>	Full Open or Full Closed	-8000 +/- 1500 or +8000 +/- 1500
General Rule for other configurations	Any amount of rotation Clockwise or counter-clockwise	 <p>(0°)</p>	50% Travel (Mid-Stroke)	0 +/- 1000

- c. Aligning the end of the magnet holder flush with the end of the mounting bracket. Secure the magnet holder with two M4 set screws.
- d. Sliding the V-Seal over the magnet holder. You can also check the magnet using ValVue software by reading sensor counts and comparing them to Table 2.
4. Secure the SVi1000 onto the mounting bracket using four M6 x 20 mm socket head cap screws.
5. Ensure no interference exists with the position sensor protrusion.

6. Ensure that the V-Seal makes contact with the skirt around the alignment ring on the SVi1000 (Figure 11).

**CAUTION**

*Do not carry the positioner by the alignment ring.*



Align the end of the magnet holder assembly with the end of the mounting bracket

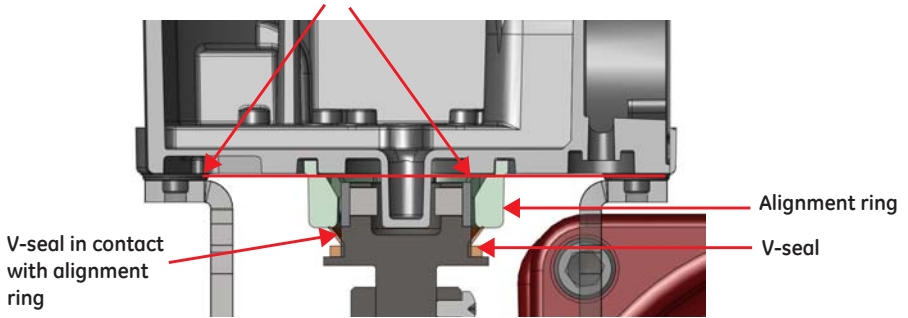

Figure 11 Camflex V-Seal

## Mounting the SVi1000 on Reciprocating Valves

This section describes the procedure for mounting the SVi1000 on Reciprocating Valves, using Masoneilan's 87/88 Multi-Spring actuators as an example. Figure 13 on page 27 shows the standard lever for all size installations. See "Integrated Magnet Assembly" on page 30 for the optional IM assembly.

Tools required:

- 7/16" Combination Wrench (2 required)
  - 3/8" Combination Wrench
  - 1/2" Combination Wrench
  - Phillips Head Screw Driver
  - M4 Hex Key
  - M3 Hex Key
1. Mount the standard reciprocating mounting bracket to the valve using two (2) 5/16 - 18 UNC cap screws.

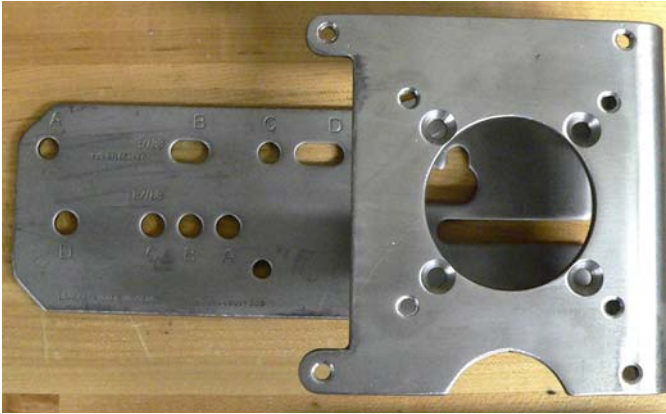

**Figure 12 Reciprocating Valve Mounting Bracket for Standard Lever**

2. Ensure that the lever is pinned to the magnet assembly and held securely by an M5 flat head screw to ensure that the magnet axis is vertical when the lever is in the valve closed position. Tighten the lever screw securely (Figure 13).

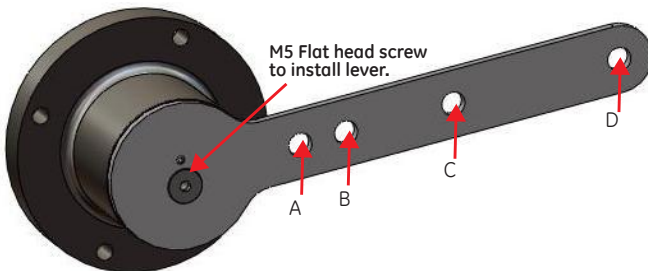

**Figure 13 Magnet Holder and Standard Lever for Reciprocating Valves**

- Select mounting hole for the stroke of the valve. Unless otherwise specified, the SVi1000 mounting assumes that the actuator is in the normal upright position. The mounting hole in the slotted opening of the mounting bracket must be left when facing the actuator, with the actuator in the upright position.

**Table 3: Reciprocating Valve Mounting Hole and Turnbuckle Length**

Actuator Size Masoneilan 87/88	Stroke	Mounting Hole	Lever Hole	Turnbuckle Length
6 and 10	0.5 - 0.8" (12.7 - 20.32 mm)	A	A	1.25" (31.75 mm)
10	0.5 - 0.8" (12.7 - 20.32 mm)	A	A	1.25" (31.75 mm)
10	>0.8 – 1.5" (20.32 - 41.5 mm)	B	B	1.25" (31.75 mm)
16	0.5 - 0.8" (12.7 - 20.32 mm)	B	A	2.90" (73.66 mm)
16	>0.8 – 1.5" (20.32 - 41.5 mm)	C	B	2.90" (73.66 mm)
16	>1.5 – 2.5" (41.5 - 63.5 mm)	D	C	2.90" (73.66 mm)
23	0.5 - 0.8" (12.7 - 20.32 mm)	B	A	5.25" (133.35 mm)
23	>0.8 – 1.5" (20.32 - 41.5 mm)	C	B	5.25" (133.35 mm)
23	>1.5 – 2.5" (41.5 - 63.5 mm)	D	C	5.25" (133.35 mm)

4. Thread the take-off rod to the actuator stem connector (Figure 14).

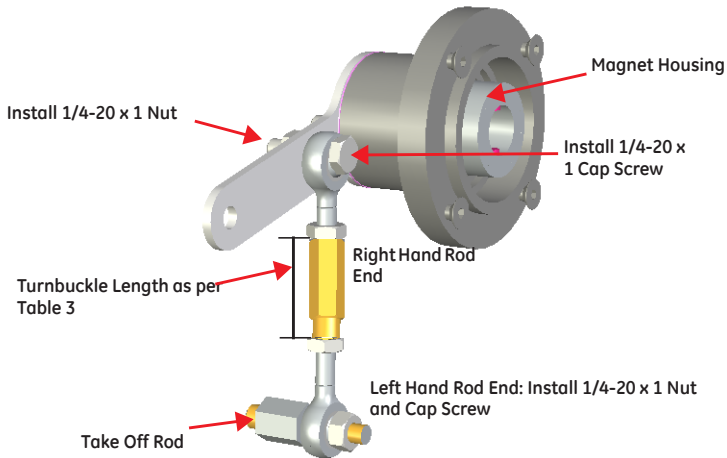

**Figure 14 SVi1000 Take Off Rod Mounting**

5. Attach the right hand threaded rod end to the lever using a 1/4 - 20 x 1" cap screw and nut (Figure 14).
6. Thread the right hand lock nut and turnbuckle onto the right hand rod end approximately two turns. Turnbuckle length is a function of actuator size. Refer to Table 3 on page 28.
7. Secure the magnet housing assembly, including the lever and right hand rod end, to the bracket using four M5 X 10 mm flat head screws.
8. Attach the left hand threaded rod end to the take-off rod with 1/4 - 20 UNC nut and thread the left hand lock nut onto the rod end.
9. Move the valve to its closed position. For air to:
  - Close: Requires using air pressure in the actuator to fully stroke the actuator.
  - Open: Vent the actuator of air pressure.
10. Thread the turnbuckle onto the left hand threaded rod end (Figure 14).
11. Adjust the turnbuckle until the hole in the lever is aligned with the alignment hole in the bracket. Tighten both turnbuckle lock nuts (Figure 14).

12. Ensure the adjustable link turnbuckle is parallel to the valve stem. Verify that the hole in the lever aligns with the alignment hole in the bracket when the valve is in the closed position. Check that the bracket is mounted using the proper holes (Figure 15).

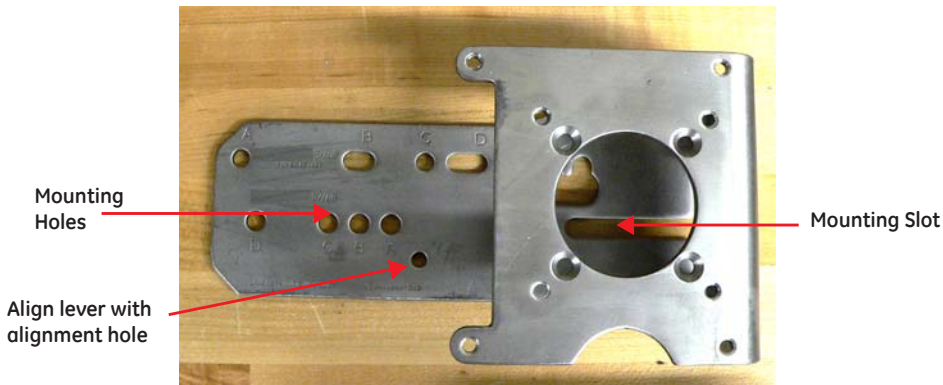
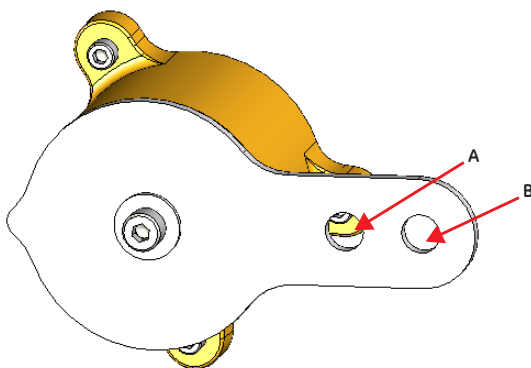

**Figure 15** Ensure Position Linearity

13. Mount the SVi1000 to the bracket and secure with four M6 socket head cap screws.

## Integrated Magnet Assembly

The IM (Integrated Magnet) assembly kit is an optional assembly intended for custom mounting by the end user for reciprocating actuators (Figure 16). This kit allows for more leeway in installation.



**Figure 16** SVi1000 Lever Installed to IM Assembly

### NOTE



*You can use a custom bracket with the IM option. Refer to drawing #720012413 for assistance.*

## Step 2: Connecting the Tubing and Air Supply

To connect the air supply:

1. Install the tubing to the air supply port. Minimum tubing diameter 1/4" (Figure 17).

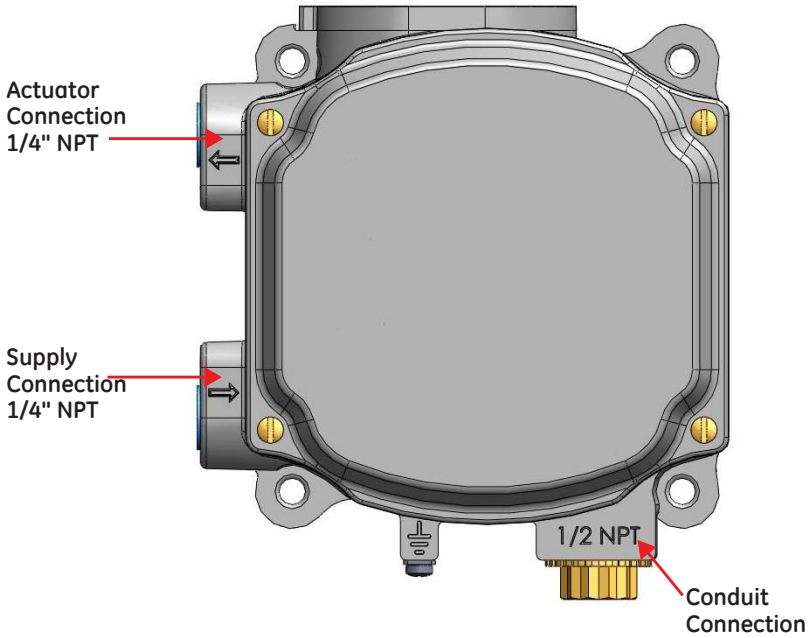

Figure 17 Air Ports

2. Pipe the output air from the output pressure port to the actuator. Minimum tubing diameter: 1/4".

### NOTE



*The SVi1000 is designed to operate with clean, dry, oil-free, instrument grade air to ANSI-ISA-57.3 1975 (R1981) or ISA-S7.3-1975 (R1981).*

3. Ensure the air supply falls within the parameters in Table 4.

**Table 4: Air Supply Requirements**

Dew Point	At least 18 °F (10 °C) below minimum anticipated ambient temperature
Particulate Matter	Filtered to 5 microns
Oil Content	Less than 1 ppm w/w
Contaminants	Free of all corrosive contaminants

4. Supply clean, dry compressed air to the filter regulator.
5. Turn on the air supply.
6. Adjust the filter regulator.  
Supply pressure must be a minimum of 5 psi above the spring range of the actuator but may not exceed the rated actuator pressure. Refer to the valve or actuator instruction manual.

## Step 3: Wiring the SVi1000

### WARNING



*Comply with current national and local regulations for electrical installation work.  
Before carrying out any work on the device, power off the instrument.*

### CAUTION



*Improperly or inadequately grounded installations can cause noise or instability in the control loop. The internal electronic components are isolated from ground. Grounding the case is unnecessary for functional purposes but grounding the case may be necessary to conform to local codes.*

*Refer to “Optional Switch Load Limits” on page 59 for guidelines on safely wiring switch load limits.*



## Wiring Guidelines

Guidelines for a successful implementation of DC current signal, DC power, and HART® communication to the SVi1000:

- Compliance voltage at the SVi1000 is approximately 9 V at the current of 20 mA. “Determining an SVI Positioner Compliance Voltage in a Control System” on page 63.
- Signal to the SVi1000 must be a regulated current in the range 3.2 to 22 mA.
- Controller output circuit must be unaffected by the HART® tones which are in the frequency range between 1200 and 2200 Hz.
- In the frequency range of the HART® tones, the controller must have a circuit impedance of more than 220 Ohms, typically 250 Ohms.
- HART® tones may be imposed by the positioner and a communication device located anywhere on the signaling circuit.
- Cabling must be shielded to prevent electrical noise that would interfere with the HART® tones, with the shield grounded.
- Shield must be properly grounded in only one place.
- For details and calculation methods for wiring resistance, and capacitance and for calculation of cable characteristics, refer to the HART® FSK Physical Layer Specification.
- For split range installations the output voltage must be sufficient to operate two positioners (11 V @ 4 mA, 9 V @ 20 mA) and the expected voltage drop in the cable.
- Use of a low impedance voltage source damages the SVi1000. The current source must be a true high impedance current limiting device. A proper current source explicitly enables adjustment of the current, not the voltage.
- Position Retransmit: when wiring this feature:
  - Use the same gauge wires as the 4-20 mA control loop.
  - Ensure that the position retransmit signal is connected to the control system’s analog input card.
  - Ensure the control loop is powered while making measurements with a meter.

### WARNING



*This process can cause the valve to move. Before proceeding be sure the valve is isolated from the process. Keep hands clear from moving parts.*

# Wiring an SVi1000 Unit

Tools required:

- Wire stripper
- Flat head screwdrivers for cover and connectors

To connect:

## CAUTION



*For proper operation, maintain signal polarity + and - respectively.*

## CAUTION



*You must read Appendix B "Optional Switch Load Limits" on page 59 before proceeding. The load across these switches must conform to the limits described in that discussion.*

1. Loosen the four (4) cover screws and remove the SVi1000 cover (Figure 18).

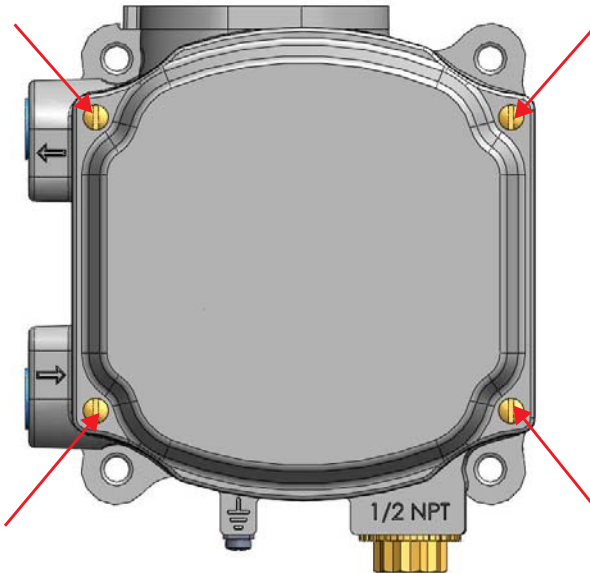

Figure 18 Front Cover

2. Connect the 4 - 20 mA input signal and the optional switches or position retransmit by:
  - a. Stripping the insulation at the end of both wires 0.43" / 11 mm.
  - b. Inserting the stripped end of the wires fully in to the appropriate terminal. Loosen the terminal screw if required to insert the wire. Refer to the label next to each screw terminal to determine the function of the terminal and correct polarity (see Figure 19 for 4 - 20 mA connections and Figure 20 on page 36 for position retransmit).
  - c. Tightening the terminal screws (to a torque of 5 to 7 lb-in).

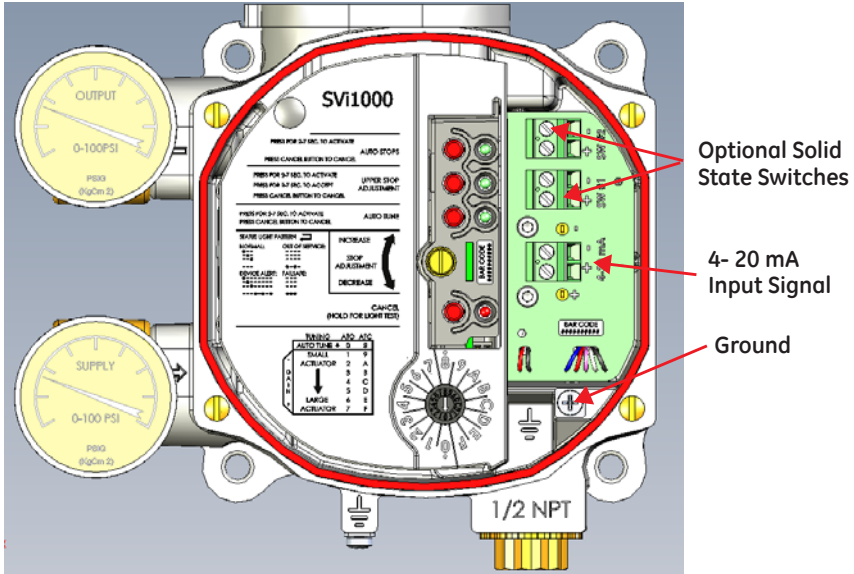
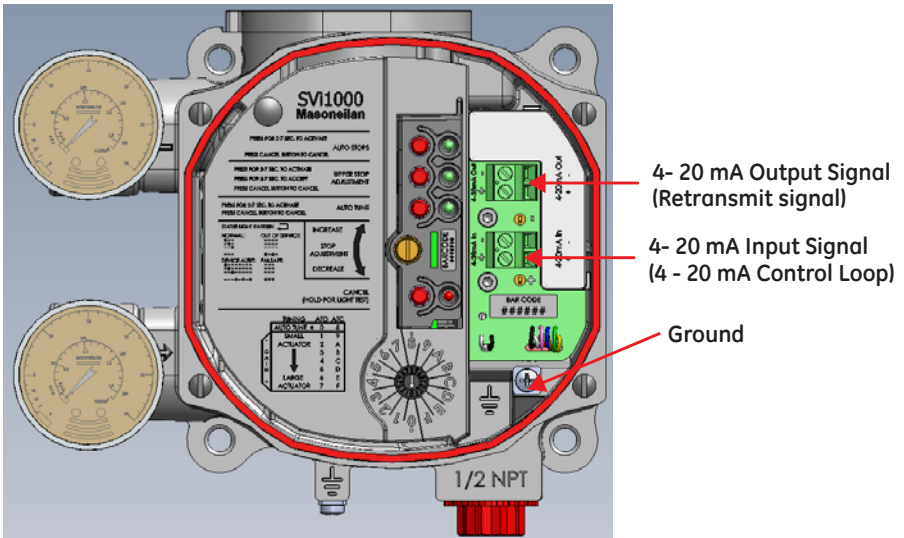

Figure 19 Connections to Electronics Module with Switches (via Interface Board)



**Figure 20 Connections to Electronics Module with Position Retransmit (via Interface Board)**

3. Proceed to “Check Out and Configuration” on page 39. Refer to “Troubleshooting Connections” on page 36 if you want to check the validity of your connections.

## Troubleshooting Connections

### Basic Unit/Optional Switches Unit

To troubleshoot control loop connections:

1. Connect a DC voltmeter across the input terminals.
  - For an input current between 4 and 20 mA the voltage varies between 11V and 9 V respective.
  - If voltage exceeds 11 V check that polarity is correct.
  - If the polarity is correct but the voltage is less than 8.05 V, then the current source voltage is not compliant.
2. Verify that source can supply 20 mA to SVi1000 input. If 20 mA is not attainable, troubleshoot the source.

## **Position Retransmit Units**

To troubleshoot control loop connections:

1. Connect a DC voltmeter across the input and output terminals.
  - For an input current between 4 and 20 mA the voltage varies between 11V and 9 V respective.
  - If voltage exceeds 11 V check that polarity is correct.
  - If the polarity is correct but the voltage is less than 8.05 V, then the current source voltage is not compliant.
2. Verify that source can supply 20 mA to SVi1000 input. If 20 mA is not attainable, troubleshoot the source.

To troubleshoot retransmit connections:

- Ensure that the retransmit circuit has a minimum input voltage of 10 V (maximum 30 V).
- Ensure the minimum retransmit current is 3.2 mA. If the SVi1000 positioner loses power and the retransmit circuit remains powered, the AO signal will be 3.2 mA.

*This page intentionally left blank.*

# 4. Check Out and Configuration

## Overview

This section provides the calibration procedures to ensure proper valve positioning, which include:

1. "Step 1: Inspect the Actuator, Linkages, or Rotary Adapter" on page 41
2. "Step 2: Verify Mounting and Linkage Adjustment" on page 41
3. "Step 3: Checking the Magnet" on page 41
4. "Step 4: Checking the Air Supply" on page 42
5. "Step 5: Verify Wiring Connections" on page 43
6. "Step 6: Configuration" on page 43

### NOTE



*Perform all procedures in this section before putting the SVi1000 into operation.*

# Notes on Aggressiveness

## Setting Aggressiveness

While the SVi1000 DTM and the DD allow you to set Aggressiveness, the pushbuttons do not. In all three methods, however, the Aggressiveness value is inherited from any previously performed tuning (Autotune or manual). Once Aggressiveness, and other tuning values are determined, they are stored in NVRAM.

The SVi1000 provides a user define Aggressiveness Level for auto-tuning, the allowable range varies from -9 to +9 where 0 (Zero) is consider normal tuning. The Aggressiveness Level influences stroking speed and over-shoot. A negative value will SLOW stroking speed and help minimized over-shoot. A positive value will INCREASE stroking speed and may add some over-shoot. The recommended values for Aggressiveness is 0 for control valves without volume boosters.

In applications with volume boosters and/or quick exhaust valves are used the Aggressiveness Level is not as influential. For Auto-tuning it is usually between 0 and 3. Reduce the volume boosters sensitivity by opening the integral bypass needle valve about 1 to 2 turns. Use caution when adjusting the needle valve so as to not to damage the seat, close gently to seat and then open 1 or 2 turns.

## Aggressiveness Dynamic

Lower values of aggressiveness lead to lower PID values and slower response and less overshoot.

Higher values lead to higher PID values and quicker response and more overshoot.

Once you have a preferred aggressiveness and you tune once, all future autotunes automatically use that same value, until user-changed.



## Step 1: Inspect the Actuator, Linkages, or Rotary Adapter

1. Verify that the mounting has not been damaged in shipment for a pre-mounted SVi1000, physically inspect the actuator and linkage.
2. Record the following information for the configuration checkout:
  - Valve Air to Open (ATO) or Air to Close (ATC)
  - Actuator pressure rating
  - Actuator spring range
  - Inherent trim characteristic of the control valve; linear, equal percentage, or other.

### NOTE



*Refer to the valve data sheet or model number of control valve.*

## Step 2: Verify Mounting and Linkage Adjustment

Inspect the mounting and make any needed adjustments before running the positioner and checking the digital configuration.

## Step 3: Checking the Magnet

There are two methods of checking the SVi1000 magnet:

- “Perform a Visual Inspection” on page 41
- “Use ValVue to Check Magnet Position” on page 42

## Perform a Visual Inspection

### Rotary Valves

- Ensure that mounting has been performed as per “Mounting the SVi1000 on Rotary Valves” on page 22.

### Reciprocating Valves

1. Ensure the adjustable link turnbuckle is parallel to the valve stem.
2. Ensure proper mounting by verifying that the hole in the lever aligns with the alignment hole in the bracket when the valve is in the closed position. Ensure the bracket is mounted using the proper holes (see Table 3 on page 28).

## Use ValVue to Check Magnet Position

To check the magnet using ValVue:

1. Connect to the positioner in accordance with the ValVue instructions.
  - a. Ensure the positioner has been installed and set up with a HART<sup>®</sup> modem in a HART<sup>®</sup> compliant communications loop, if required, install ValVue on the computer that is connected to the HART<sup>®</sup> modem.
  - b. Run ValVue.
  - c. Select the installed positioner from the list of *Connected Devices*.
  - d. Select the **Check** tab to view the current operating conditions of the selected positioner.
2. Read Raw Position data. When the valve is:
  - Closed, the value should be between – 1000 and +1000 for a reciprocating valve or a 60° rotation rotary valve.
  - At mid-travel, the value should be between –1000 and +1000 for a greater than 60° rotation rotary valve.

## Step 4: Checking the Air Supply

To check the air supply:

1. Turn on the air supply.
2. Adjust the filter regulator.
3. Supply pressure must be a minimum of 5 psi greater than the spring range of the actuator but may not exceed the rated actuator pressure. Refer to the valve or actuator instruction manual.
4. Inspect the tubing connections between the filter-regulator and the positioner for leaks.
5. Verify that the tubing is not bent or crushed.
6. Verify that all fittings are leak tight.

### CAUTION



*Do not use Teflon pipe seal tape. The Teflon tape can shred into particles that are harmful to the pneumatic components.*

## Step 5: Verify Wiring Connections

See C “Determining an SVI Positioner Compliance Voltage in a Control System” on page 63.

### CAUTION



*Improperly or inadequately grounded installations can cause noise or instability in the control loop. The internal electronic components are isolated from ground. Grounding the case is unnecessary for functional purposes but grounding the case may be necessary to conform to local codes.*

### NOTE



*For split range installations the output voltage must be sufficient to operate two positioners (11 V @ 4 mA, 9 V @ 20 mA) and the expected voltage drop in the cable.*

## Step 6: Configuration

This section describes configuration using the local user interface pushbuttons. You can also use ValVue and a PC with a HART® modem or a HART® Handheld Communicator. 5 “ValVue Software and the SVi1000” on page 49 describes ValVue software functions.

Prior to changing the SVi1000 configuration, check the existing configuration. Use the procedures that follow to: run auto stops, run open stop adjustment and perform preset or auto tune.

### WARNING



*These procedures can cause the valve to move. Before proceeding ensure the valve is isolated from the process. Keep hands clear from moving parts.*

## Auto Find Stops

The process first exhausts the actuator and measures the position, then fills the actuator and measures the position. From these measurements the valve position is determined. Correction can be made for nominal valve travel if it is less than full travel. To perform auto find stops:

1. Set the air action (0-7 for ATO or 8-F for ATC).
2. Press auto find stops button until green LED 1 illuminates, then release (*approximately 2 seconds to turn on and release before 7 seconds*). The unit goes into a Commission Process and green LED 1 blinks until the process completes. The auto find stops process occurs. When the process is complete, the unit automatically returns to Normal mode.

Press **Cancel** to abort the process and the green LED 1 goes off, the device returns to Normal mode and no changes occur.

# Open Stops Adjustments

In some valves the stem travel exceeds the nominal valve travel. The SVi1000 allows you to compensate for this so that the valve position reads 100% at the nominal travel. The acceptable range is between 60%-100% of possible mechanical travel.

To perform open stops adjustments:

1. Press the upper stop adjustment button for two to seven seconds, until green LED 2 illuminates, then release. Green LED 2 flashes.
2. Move the valve to the desired location via the *Open Stop Adjustment Screw* (Figure 21).

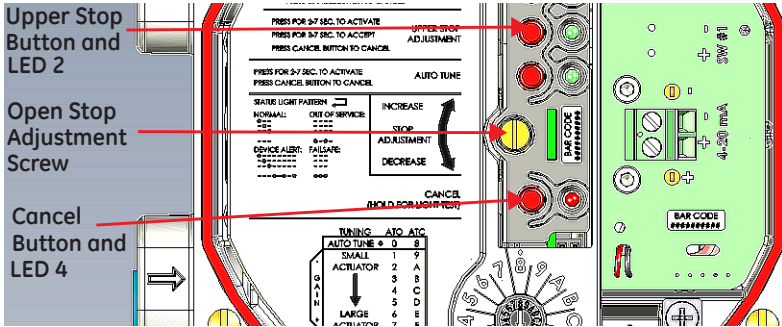

Figure 21 Open Stop Adjustment Screw

3. Press the upper stop adjustment button for more than two seconds. The green light goes off, the new stop is saved in the device and the unit is put into Normal mode. Press **Cancel** to abort the process and the green LED 1 goes off, the device returns to Normal mode and no changes occur.

# Tuning

Methods for tuning the SVi1000:

- Presets; The fastest and easiest commissioning is to use a preset tuning for the actuator in use ("Preset Tune"). Using presets saves time as you do not run Auto Tune.
- Auto Tune: If desired, run Auto Tune ("Auto Tune" on page 48).
- PID Settings: The third method is to manually tune PID settings for fine tuning, if desired. See the online help.

## Preset Tune

Preset tuning is done according to valve/actuator size. Figure 22 shows the graphic that appears on the local user interface. As valve size increases values increase from 1 to 7 and 9 to F. 0 and 8 are reserved for auto tuning ATO and ATC valves, respectively.

Preset tuning becomes active immediately.

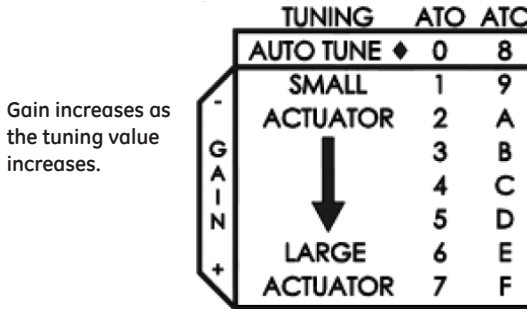

Figure 22 Preset Tuning Values

To use preset tuning values:

- Use the *Configuration Selection Switch* to select a preset tuning value (Figure 23).

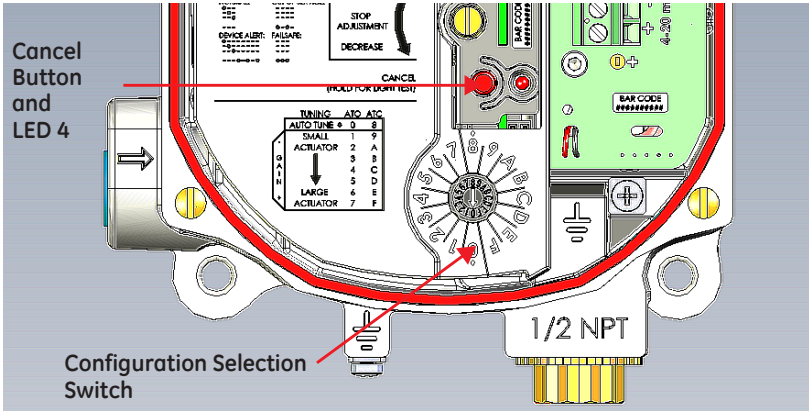



Figure 23 Configuration Selection Switch

Table 5 gives a guideline for setting the Configuration Selection Switch with regard to actuator size.

**Table 5: Actuator Settings Configuration Selection Switch Guidelines**

ATO	ATC	Actuator Size	Examples
1	9		1) 4.5" Camflex (7-15 SR)
2	A		2) 6" Camflex (7-15 SR)
3	B		3a) #6, 87(ATC), 3-15 SR 3b) #6, 88(ATO), 11-23 SR 3c) #10, 87 (ATC), 3-15 SR 3d) #10, 88(ATO), 11-23 SR
4	C		4s) #6, 87(ATC), 6-30 SR 4b) #6, 88(ATO), 21-45 SR 4c) #10, 87 (ATC), 6-30 SR 4d) #10, 88(ATO), 21-45 SR
5	D		5a) #16, 87(ATC), 3-15 SR 5b) #16, 88(ATO), 11-23 SR 5c) #23, 87 (ATC), 3-15 SR 5d) #23, 88(ATO), 11-23 SR
6	E		6a) 7" Camflex, 7-24 SR 6b) 9" Camflex, 7-24 SR
7	F		7a) #16, 87(ATC), 6-30 SR 7b) #16, 88(ATO), 21-45 SR 7c) #23, 87 (ATC), 6-30 SR 7d) #23, 88(ATO), 21-45 SR

# Auto Tune

Auto Tune normally takes three to ten minutes and strokes the valve in large and small steps to set the PID positioning parameters for best response to an input signal change.

This procedure overrides any previous configuration done using presets.

To auto tune the SVi1000:

1. Set the *Configuration Selector Switch* to the auto tuning parameter (Figure 24):
  - 0 for an ATO valve (Air to Open application)
  - 8 for an ATC valve (Air to Close application).

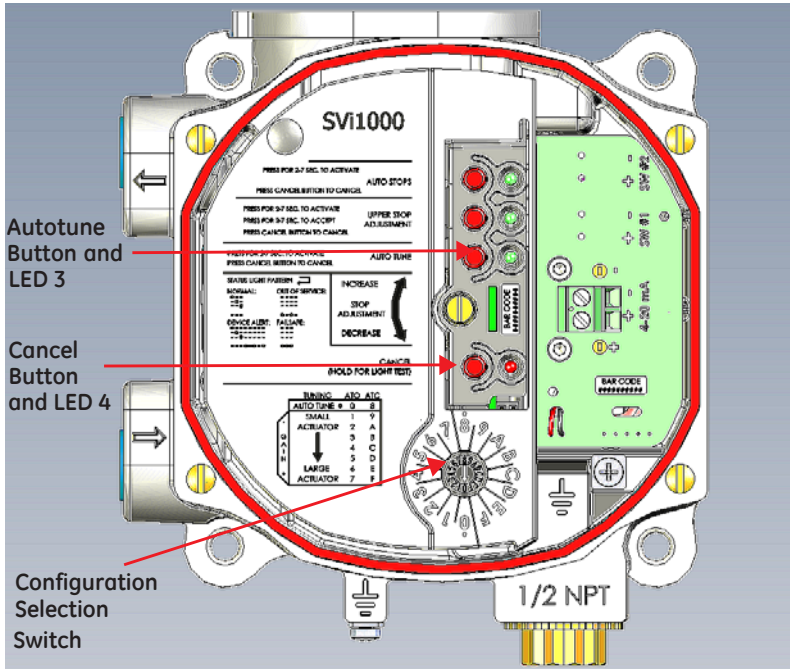

Figure 24 Configuration Selection Switch

2. Press the **Autotune** button until green LED 3 lights, then release (*approximately 2 to 7 seconds*). The unit goes into a Commission Process and green LED 3 blinks. The autotune process occurs.  
When the autotune process is complete the unit automatically returns to Normal mode.  
Press **Cancel** to abort the process and the green LED 3 goes off, the device returns to Normal mode and no changes to the tuning parameters occur.



# 5. ValVue Software and the SVi1000

## ValVue Overview

This section generally discusses the ValVue software that can be used to configure the SVi1000 from a HART® configured laptop.

### NOTE



*A cloning feature is available for the SVi1000 positioner. Cloning transfers the configuration and calibration parameters from one device to another. Cloning operations are to be performed only by BHGE personnel or qualified channel partners trained on properly performing the cloning function. This feature is not available during normal ValVue operation. Contact BHGE or a channel partner for more information.*

## ValVue and SVi1000 DTM Trial Version

You must download the ValVue software and the SVi1000 DTM software, then install to configure and use the SVi100. See “ValVue and SVi1000 DTM Software Installation” on page 50.

The SVi1000 DTM software and the ValVue software comes with a trial version of ValVue. For 60 days after the initial installation, The ValVue software provides the FDT frame capability in which the SVi1000 DTM software operates. The SVi1000 DTM software provides the capability of configuring, calibrating, diagnosing, trending and much more. After the 60 day trial period ValVue must be registered for continued use.

## ValVue and SVi1000 DTM Software Installation

This section discusses the ValVue software used to configure the SVi1000 from a HART<sup>®</sup> configured laptop. Minimum requirements are:

- Windows<sup>®</sup> 7, Windows<sup>®</sup> Server 2003 SP3, Windows<sup>®</sup> Server 2008 SP2, Windows<sup>®</sup> 8, Windows<sup>®</sup> Server 2012
- 64 MB RAM
- Hard drive available space 1 G
- Available Serial or USB port (or Bluetooth)
- A HART<sup>®</sup> modem and appropriate cables

## Masoneilan Software

### NOTE



*For ValVue 3 or DTM registration, you must run the frame application (i.e. ValVue 3, PACTware etc) as Administrator. For instance, for ValVue 3, select the icon or ValVue 3 in the Start menu, right-click and select **Run as Administrator**.*

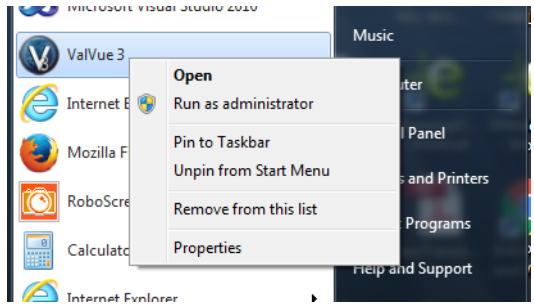

*This also applies when using Masoneilan DTMs inside of PACTware<sup>®</sup> or other vendor and updating licensing.*

*If you are performing these functions on a Masoneilan DTM using ValVue 3 and ValVue 3 is run as an Administrator, then the DTMs inherit the Windows Administrator properties from ValVue 3.*

## Download and Install ValVue 3

1. Go to the *Resource Library* (<https://valves.bhge.com/resource-center>) and enter *ValVue* in the search field (arrow in Figure 25).

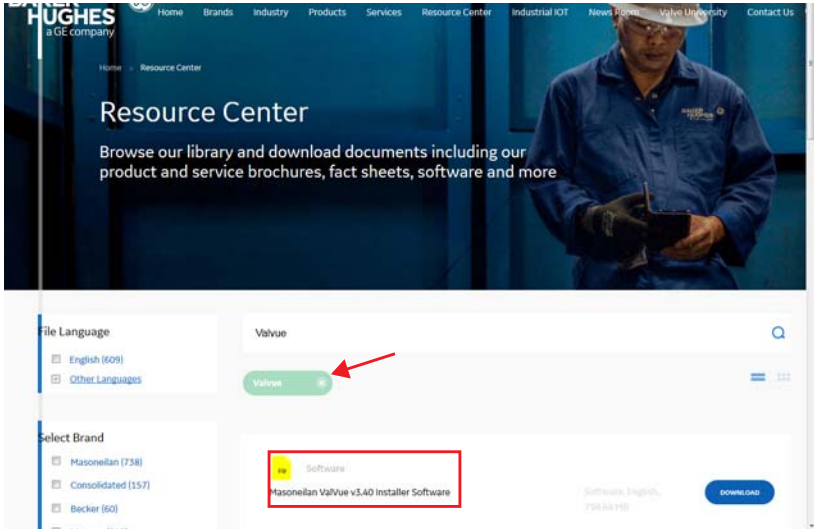

Figure 25 Download Center: Search for Valve 3

The results appear (red box in Figure 25).

2. Click **Download** below *ValVue Installer Download* and Figure 26 appears.

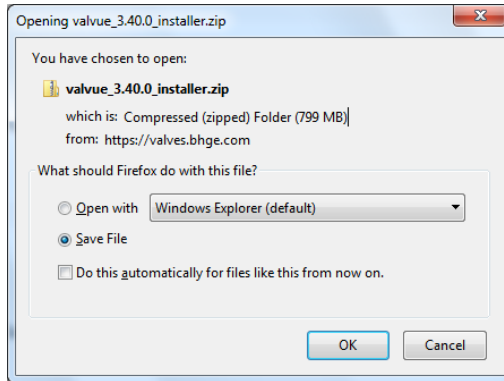

Figure 26 Opening Dialog

### NOTE



*The dialog that appears for download varies by the program used.*

3. Click **Save File**, click **OK** and it saves by default to the *Windows Downloads* folder.

**NOTE**



For fastest installation, save the download file to your laptop/PC. *Don't install from the website.*

4. Open *Windows Explorer* and click the **Windows Downloads** folder.

**NOTE**



*If you have a previous install of ValVue 3 you are prompted to uninstall first and then you must run the installer again to finish the upgrade.*

**NOTE**



*If you are upgrading from ValVue 2.x you must update the SQL database location to match ValVue 3's.*

5. Unzip the files to a folder on your local drive.
6. Right-click the installer, and select **Run as Administrator**, and follow the instructions to install.

**NOTE**



*The last dialog contains useful information on where to find help resources (Figure 27).*

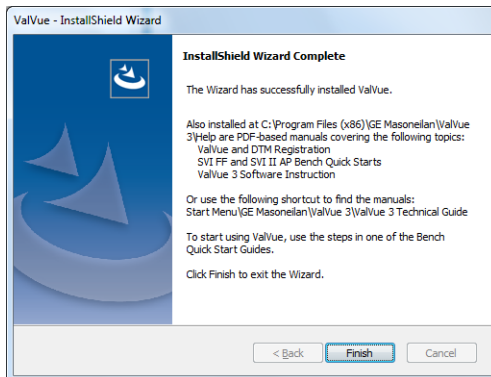

**Figure 27** InstallShield Wizard Complete

# Download and Install the SVi1000 DTM

1. Go to the *Resource Library* (<https://valves.bhge.com/resource-center>) and enter *SVI1000 DTM* in the search field (red arrow in Figure 28).

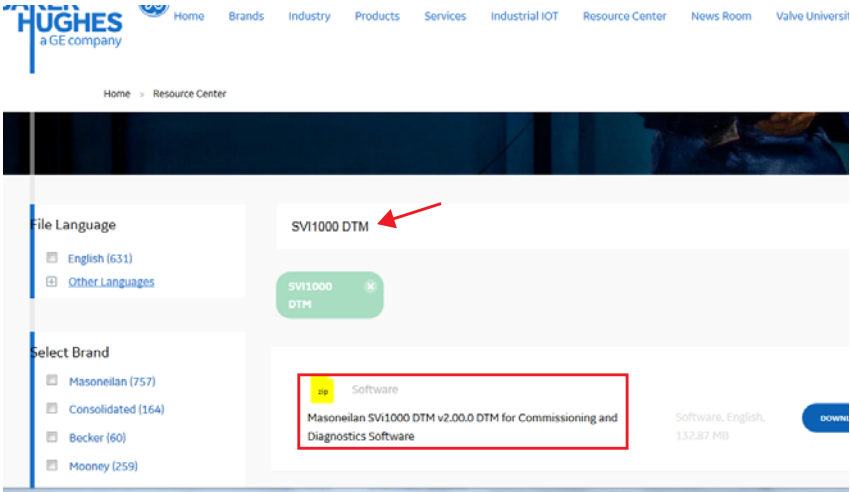

Figure 28 Download Center: Search for SVi1000 DTM

The results appear (red box in Figure 28).

2. Select **Download** below *SVi1000 DTM* and Figure 29 appears.

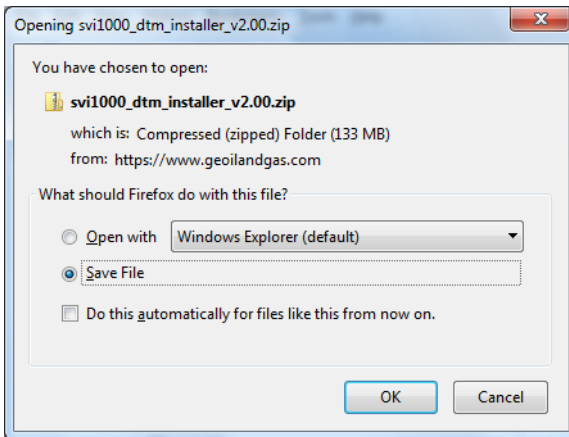

Figure 29 Opening Dialog

**NOTE**



*The dialog that appears for download varies by the program used.*

3. Click **Save File**, click **OK** and it saves to the *Windows Downloads* folder.

**NOTE**



*For fastest installation, save the download file to your laptop/PC. Don't install from the website.*

4. Open *Windows Explorer* and click the **Windows Downloads** folder.

**NOTE**



*If you have a previous install of the SVi1000 DTM you are prompted to uninstall first and then you must run the installer again to finish the upgrade.*

5. Unzip the files to a folder on your local drive.
6. Right-click the installer, and select **Run as Administrator**, and follow the instructions to install.

# HART® Handheld Communicator

While the SVi1000 is equipped with a local user interface, checkout and configuration can also be performed using the standard HART® communications interface.

Connect the HART® Handheld Communicator (HHC) to the SVi1000 as shown in Figure 30. Refer to the HART® Communicator product manual included with the HHC or other HART® Communication devices.

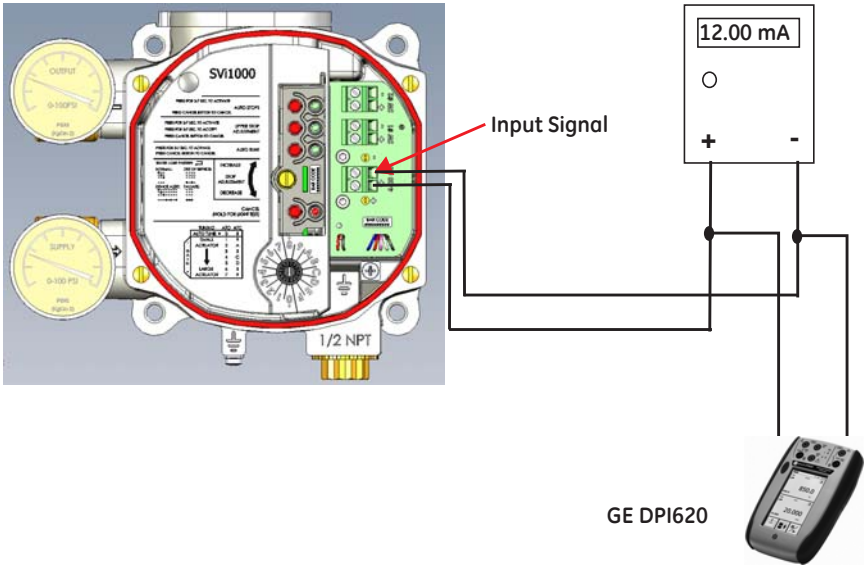

Figure 30 SVi1000 HART® Communicator Connections

*This page intentionally left blank.*



# Appendix A. SVi1000 Theory

## Introduction

The SVi1000 provides for reliable operations of control valves with utmost simplicity in setup and commissioning. It is uniquely equipped with a non-contact travel sensor allowing for accurate positioning and maintenance free operations. The pneumatic train of the SVi1000 is a dual-stage amplification system with stainless steel wetted parts for durability. Using HART® eDDL and FDT-DTM technologies, the Masoneilan SVi1000 positioner provides interoperability with leading control systems suppliers.

## SVi1000 Setups

A typical system setup is shown in Figure 31, *General Purpose Installation* schematic.

Wiring diagrams are generalized, actual wiring must adhere to electrical installation section of manual and local electrical codes.

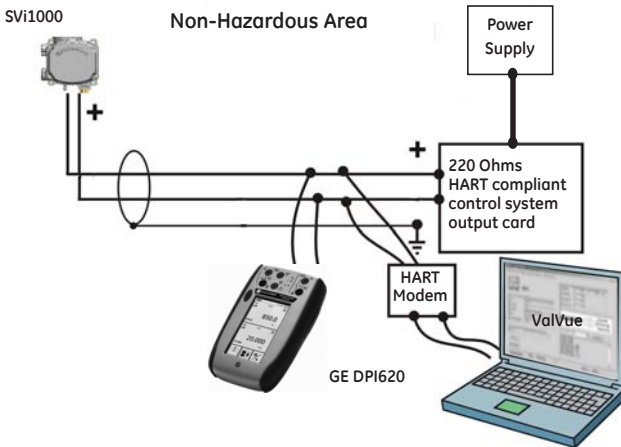

**Figure 31** General Purpose Installation

For information and diagrams to install the SVi1000 when located in a hazardous area protected by Intrinsically Safe wiring practices, refer to ES-761 the *Intrinsically Safe Wiring Requirements* section ( "Hazardous Location Installation and Declaration of Conformity" on page 72).

## Grounding Practices

To ensure proper grounding make sure that case, signal, and ground connections are made in compliance with the plants normal grounding practices. Any point in the loop can be referenced to ground, but there must never be more than one ground point. Normally ground is connected at the controller or at the intrinsic safety barrier.

The case grounding screws are located on the outside of the case. The case is isolated from all circuitry and can be grounded locally in accordance with applicable codes.

## Compliance Voltage in Single Drop Current Mode

The SVi1000 requires 9.0 V at 20 mA and 11.0 V at 4 mA. Typical HART® devices require MORE voltage at higher current and MORE current source have LESS voltage available at higher current. The SVi1000 is unique in that it requires LESS voltage at higher current which complements the characteristic of the source requiring only 9 V at 20 mA.

# Appendix B. Optional Switch Load Limits

## General Configuration Notes

The SVi1000 supports two identical contact outputs, SW #1 and SW #2 (Digital Output switches), that can be logically linked to status bits.

The switches are polarity sensitive and must be connected only to a DC circuit. The switch (+) terminal must be electrically positive with respect to the (-) terminal. If the (+) terminal is electrically negative with respect to the (-) terminal, then the switch will conduct, regardless of switch state.

**If the switch is connected directly across the power source, the current will be limited only by the capacity of the power source and the switch can be damaged.**

This section discusses the necessary precautions when configuring a system.

Without a load, when the switch is on (closed) the external voltage would be dropped across the switch. **This damages the switch** (Figure 32).

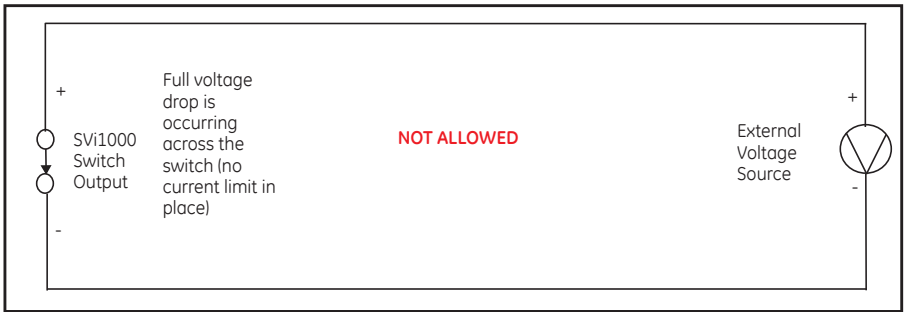

Figure 32 Switch Installation Drawing without Load: Configuration **Not Allowed**

	Switch OFF	Switch ON
$V_{\text{SWITCH}}$	30 VDC max.	$\leq 1 \text{ V}$ (Switch saturation voltage)
$I_{\text{SWITCH}}$	$\leq 0.200 \text{ mA}$ (Switch leakage current)	1 A max.

### CAUTION



*Incorrect polarity connection results in an effectively closed connection.*

## CAUTION



Consult with qualified personnel to ensure that electrical requirements for the switch are met.

The maximum voltage that can be applied to the digital switch outputs is 30 VDC. This is an open circuit parameter (the digital switch is in the open state). Under open circuit conditions, the switch current will be less than 0.200 mA.

The switch maximum current rating is 1 A. When the switch is ON, the typical switch voltage is  $\leq 1V$ .

When the switch is on (closed) the external voltage must be dropped across the load (Figure 33).

## CAUTION



The load must be designed such that the current in the circuit is  $\leq 1 A$  at all times. Some 3rd party devices, such as incandescent lamps or solenoids, require surge and back EMF protection to prevent voltage spikes.

## Inductive Load, Solenoid, Incandescent Lamp Configuration

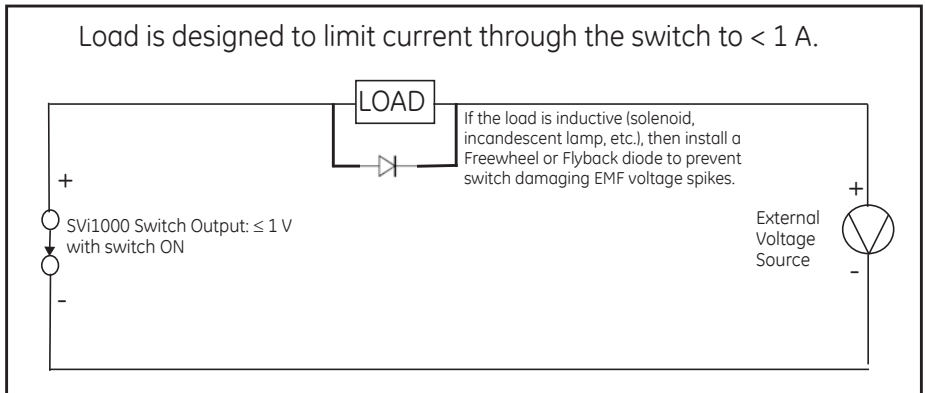

Figure 33 Simplified Switch Installation Drawing: Correct Configuration

## Distributed Control Systems Configurations

This section gives guidance for configuration in a DCS application. Figure 34 gives two generalized drawings that cover DCS applications to ensure switch safety.

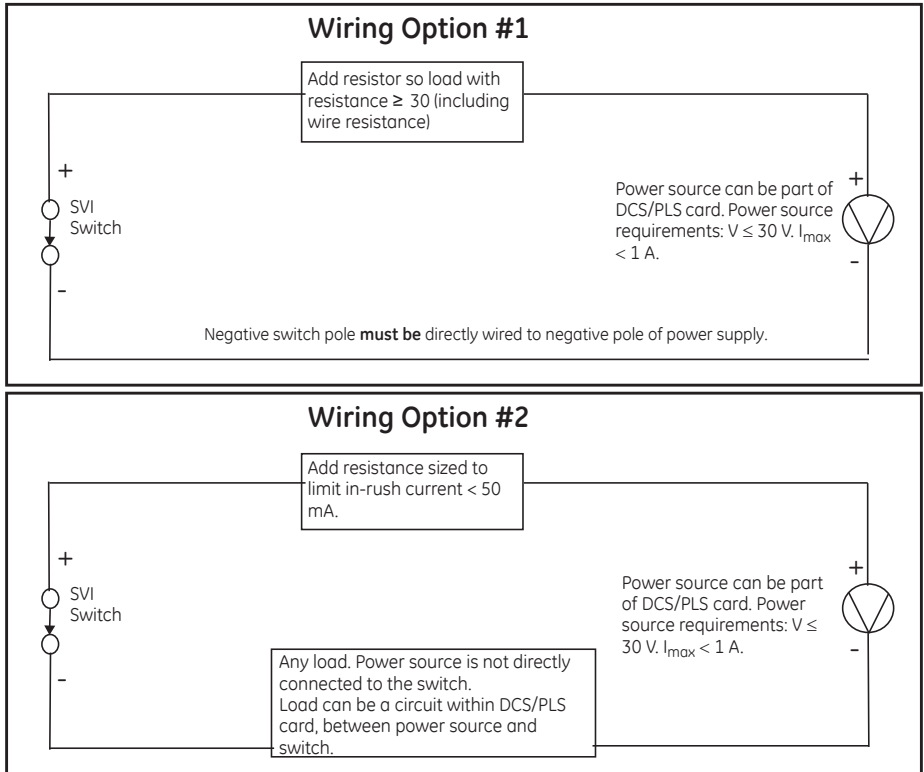

Figure 34 DCS Switches Wiring Options

### Configuration Considerations

- A typical value for 24 AWG cable about 0.025 Ohm/ft (see Wiring Option #1).
- If IS barrier is a combination of fuse, resistor and Zener diode then the connection is shown in Option #2. The barrier must have adequate resistance to limit inrush current, as the fuse cannot limit inrush current (see Wiring Option #2).

# Optional Retransmit Output

## Introduction

The SVi1000 supports a 4-20mA Position Retransmit Feedback option. The retransmit output requires a DC power source (10V~30V) to properly function. The signal could be input into a DCS/PLC analog input module to read out the current valve position.

The output terminals are polarity sensitive and must be connected only to a DC circuit. The Retransmit (+) terminal must be electrically positive with respect to the (-) terminal.

In normal working conditions, the retransmit output follows the valve position by outputting a 4-20mA analog signal. If the positioner stops working due to loss of loop power or malfunctioning, the retransmit output stays at around 3.2 mA.

This section discusses the necessary precautions when configuring a system.

### CAUTION



*An incorrect polarity connection will result in device not properly functioning or with internal circuitry damage.*

### CAUTION



*Consult with qualified personnel to ensure that electrical requirements for the switch are met.*

The external series resistor is normally located in a DCS/PLC analog input module, so that the valve position (current) can be transferred into voltage (Figure 35).

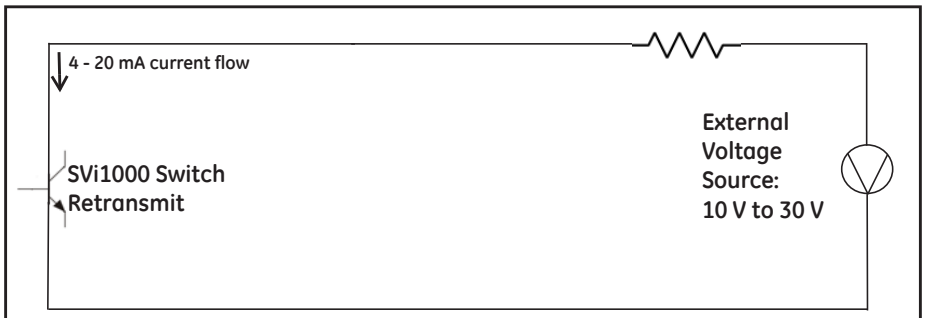

Figure 35 Simplified Retransmit Option Installation Drawing

# Appendix C. Determining an SVI Positioner Compliance Voltage in a Control System

This discussion explains how to determine compliance voltage for an SVI positioner. It applies to the SVI II AP, SVI II ESD, SVI II APN and SVI1000.

A definition of compliance voltage is: The voltage that must be available at the control system output in order to drive the control current through the SVI II AP and all the resistive devices in series with it.

Measuring the voltage across the SVI II AP terminals doesn't give the true available system compliance voltage as the positioner self-regulates voltage as current flows through it. Additionally, it also doesn't confirm what system voltage is available under load conditions. *Therefore, if compliance testing needs to be done, it is best done before installation.*

Use a 1K potentiometer as this is the maximum for most analog output cards and as at 20 mA this equals 20 VDC, which is a sufficient maximum.

## Compliance Test Set-Up

1. Configure a test set-up as in Figure 36.

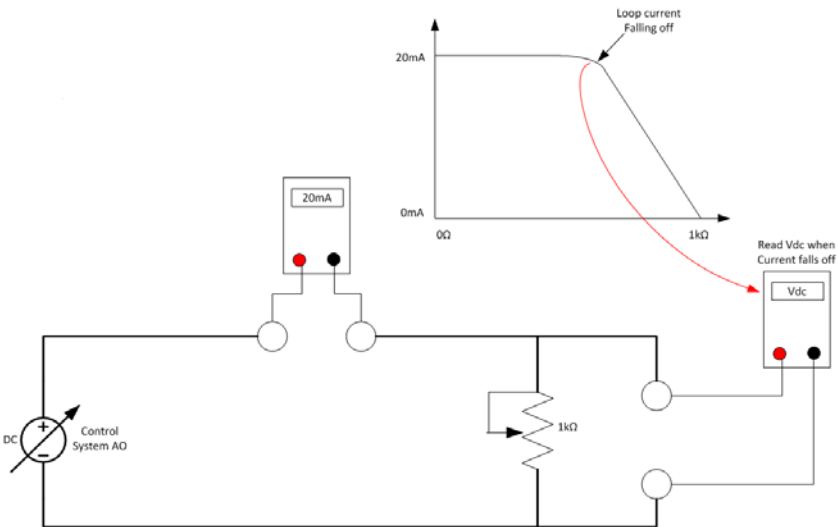

Figure 36 Compliance Voltage Test Set-Up

2. Send 4 mA to the test set-up.
3. Increase the potentiometer value until the loop current reaches 3.95.
4. Read the voltage across the potentiometer, which should be > 11 VDC. This is the available system voltage at the minimum output.

5. Send 20 mA to the test set-up.
6. Increase the potentiometer value until the loop current reaches 19.95 mA.
7. Read the voltage across the potentiometer, which should be > 9 VDC. This is the available system voltage at the maximum output.

Table 6 lists some compliance voltage readings at positioner terminals at several currents.

**Table 6: Expected Voltage Range at Positioner Terminals**

Current	Compliance Voltage Requirement at Positioner Terminals	Expected Voltage Measured at Positioner Terminals
4 mA	11 V	10 to 11 V
8 mA	10.5 V	9.5 to 10.5 V
12 mA	10 V	9 to 10 V
16 mA	9.5 V	8.5 to 9.5 V
20 mA	9 V	8 to 9 V



# Appendix D. Specifications, Spare Parts and References

## Physical and Operational Specifications

This section provides the physical and operational specifications for the SVi1000. Specifications are subject to change without notice

**Table 7: Environmental Specifications**

Parameter	Storage & Transport (Packaged)
Operating Temperature Limits	-40 °F to 185 °F (-40 °C to 85 °C)
Storage Temperature Limits	-58 °F to 200 °F (-50 °C to 93 °C)
Temperature Effect	< 0.005% / °F typical; -40 °F to 180 °F (< 0.01% / °C typical; -40 °C to 82 °C)
Supply Pressure Effect	0.05% per psi (.73% per bar)
Operating Relative Humidity	5 to 100% non-condensing
Storage Relative Humidity	0 to 100% non-condensing
Humidity Effect	Less than 0.2% after 2 days at 104 °F (40 °C), 95% Relative Humidity.
Electromagnetic Compatibility Electrostatic	<input type="checkbox"/> IEC 61514 Industrial-Process Control systems - methods of evaluating the performance of intelligent valve positioners with pneumatic outputs. <input type="checkbox"/> IEC 61326 Electrical equipment for measurement, control and laboratory use - EMC requirements.
Fast Transient Burst	No effect at 2 kV (Coupling clamp EN61000-4-4 or IEC1000-4-4).
Vibration Influence Measured at SVi1000 Housing	<input type="checkbox"/> 4 mm at 5 - 15 Hz - Negligible <input type="checkbox"/> 2 G at 15 - 150 Hz Less than 2 % of span <input type="checkbox"/> 1 G at 150 - 2000 Hz - Less than 2% of span
Housing	Tropicalized with positive pressure
Magnetic Field Influence	Negligible at 100 A/m 50/60 Hz (EN61000-4-8) CE MARK The SVi1000 conforms to the requirements of the ATEX 94/9/EC and EMC 2014/30/EU directives.

**Table 8: Operational Specifications**

Accuracy	+/- 1.0% (typical or less) Full Span
Hysteresis and Deadband	+/- 0.3% Full Span
Repeatability	+/- 0.3% Full Span
Conformity	+/- 0.5% Full Span
Start-Up Drift	Less than 0.02% in first hour
Long Term Drift	Less than 0.003% per month
Position Travel Limits	<input type="checkbox"/> Rotary: 18 - 140° <input type="checkbox"/> Reciprocating: 0.25" - 2.5" (6 mm - 64 mm) <i>Note: Above 2.5" (64 mm) consult factory for mounting instructions.</i>
Flow Characteristics Applied in addition to the control valve's inherent characteristic.	<input type="checkbox"/> Linear <input type="checkbox"/> Equal Percentage (of 50:1 or 30:1) <input type="checkbox"/> Camflex <input type="checkbox"/> Quick Opening (inverse of 50:1 equal percentage) <input type="checkbox"/> User Configurable
Tight Shut Off	0 -20% of input
Position Auto Tune SVi1000 performs automatic determination of the optimal valve position control parameters. In addition to P, I, D, the position algorithm uses damping, symmetry for exhaust and fill time constants, dead zone and magnitude characterization parameters. Auto Tune is optimized for 5% step changes with negligible overshoot. After the Auto Tune process is completed, the user can further adjust the positioner tuning parameters to more conservative or to more responsive values.	<input type="checkbox"/> Proportional gain: 0 to 5000 <input type="checkbox"/> Integral time: 0 to 100 seconds - displayed as 0 to 1000 (1/10s) <input type="checkbox"/> Derivative time: 0 to 200 ms <input type="checkbox"/> Dead Zone: 0 to +/-5% (0 to 10% dead-band) <input type="checkbox"/> Padj: +/- 3000 (depends on P) <input type="checkbox"/> Beta (non-linear gain factor): -9 to +9 <input type="checkbox"/> Position compensation coefficient: 1 to 20 <input type="checkbox"/> Boost: 0 to 20
Stroking Time	0 to 250 seconds
Full open position adjustment	60 to 100% of actual travel
Start Up Time (from no power)	Less than 500 ms

**Table 8: Operational Specifications (Continued)**

Minimum current to maintain HART®	3.4 mA
HART® Command#3 Mapping	<input type="checkbox"/> HART® 4-20 mA input signal <input type="checkbox"/> PV= Valve Position, 0-100% <input type="checkbox"/> SV = N/A <input type="checkbox"/> TV = Reserved <input type="checkbox"/> QV = Reserved

**Table 9: Input Signal and Power, Specifications**

Power Supply	Loop powered from 4-20 mA control signal
Compliance Voltage Rating	9.0 V at 20 mA, 11.0 V at 4.0 mA
Minimum Current Signal to Start Up	3.2 mA
Minimum Input Span for Split Range Operation	5 mA
Upper Range Value for Split Range Operation	8 mA to 20 mA
Lower Range Value for Split Range Operation	4 mA to 14 mA
Wire Size	12/28 AWG
Strip Length	0.43 in / 11 mm
Digital Communication	HART® Communication protocol revision 5 (firmware version 2.2.1) and 7 (firmware version 3.1.1 and later).

**Table 10: Construction Material Specifications**

Housing and Cover	Low Copper Aluminum Alloy
Weight	<input type="checkbox"/> SVi1000: 3.2 lbs./ 1.451 kg <input type="checkbox"/> SVi1000 SW/G/IM: 4.1 lbs./ 1.860 kg
Relay	Nitrile diaphragms, Polycarbonate
I/P Motor	430 stainless steel, Low Copper Aluminum Alloy, 300 series stainless steel, nitrile diaphragm
Magnet Holder	Corrosion Protected Anodized Aluminum 6061 T6

**Table 10: Construction Material Specifications**

Pole Ring	416 stainless steel
Levers	300 Series stainless steel

**Table 11: System Connectivity**

HART® Physical Device Type	Positioner; HART® cmd rev 5 or 7, Device type 204 (0x00cc)
DD Registered with the Field Comm® Group	Yes
Integration with HART® Host software	ValVue standalone, ValVue AMS SNAP-ON application available, Plug-In Application For Yokogawa® PRM, ValVue For Honeywell® FDM, Device Type Manager (DTM) for FDT® Host

**Table 12: Pneumatics Single Acting Standard Flow**

Air Supply	Dry, oil-free, 5 micron filtered air (per ISA S7.3)
Action	Direct Acting
Supply Pressure	15 to 100 psi max. (1.03 to 7 Bar) Regulate 5 psi minimum above actuator spring range. Do not exceed actuator rating.
Air Delivery	<input type="checkbox"/> 6.1 scf/min (283 L/min.) at 30 psi (2.1 bar) supply <input type="checkbox"/> 8.7 scf/min. (470 L/min.) at 60 psi (4.2 bar) supply <input type="checkbox"/> 11 scf/min. (660 L/min.) at 90 psi (6.3 bar) supply
Air Capacity (flow coefficient)	<input type="checkbox"/> Loading CV = 0.30 <input type="checkbox"/> Venting CV = 0.40
Air Consumption	<input type="checkbox"/> 0.19 scf/min. (5.4 L/min.) at 30 psi (2.1 bar) supply <input type="checkbox"/> 0.30 scf/min. (8.5 L/min.) at 60 psi (4.2 bar) supply <input type="checkbox"/> 0.40 scf/min. (11.4 L/min.) at 90 psi (6.3 bar) supply
Air Supply Failure	On supply failure the actuator output fails to atmosphere. Some overshoot may occur when air pressure returns after a period without air supply pressure.
Loss of Input Signal	Actuator Output fails to atmosphere
Output Pressure	0-100 psi (6.9 bar) max

**Table 13: SVi1000 Model Numbering**

<b>Model Number</b>	<b>Configuration</b>
SVi1000	Assembly
SVi1000 /SW	Assembly with switches
SVi1000 /G	Assembly with gauges
SVi1000 /SW/G	Assembly with switches and gauges
SVi1000 /PR	Assembly with position retransmit
SVi1000 /PR/G	Assembly with position retransmit and gauges
<b>With Integrated Magnet</b>	
SVi1000 /IM	Assembly with integrated magnet
SVi1000 /G/IM	Assembly with gauges and integrated magnet
SVi1000 /SW/IM	Assembly with switches and integrated magnet
SVi1000 /SW/G/IM	Assembly with switches, gauges and integrated magnet
SVi1000 /PR/IM	With position retransmit and integrated magnet
SVi1000 /PR/G/IM	With position retransmit, gauges and integrated magnet

# Spare Parts

Spare part kits available include:

- SVi1000 Position Retransmit Main Electronics Assembly and Terminal Board (Part Number 720045089-999-000)
- SVi1000 IP Replacement (Part Number 720045087-999-000)
- SVi1000 Housing Cover Replacement (Part Number 720045085-999-000)
- SVi1000 Position Retransmit Terminal Board Electronic Assembly (Part Number 720045084-999-000)
- SVi1000 Switch Terminal Board Electronic Assembly (Part Number 720045083-999-000)
- SVi1000 Main Electronics Assembly (Part Number 720045081-999-000)
- SVi1000 Basic Terminal Board Electronics Assembly (Part Number 720045082-999-000)
- SVi1000 Pressure Gauges Mounting (Part Number 720023182-999-0000)
- Integral magnet assembly (Part Number 720044034-999-0000)

# Hazardous Location Installation and Declaration of Conformity

The following pages provide the agency approved installation procedure for hazardous locations, which is followed by the Declaration of Conformity.

## **WARNING**



*The installation procedure is accurate at time of print. For further hazardous installation information please consult the factory.*





# ES-761

## SPECIAL INSTRUCTIONS FOR INSTALLING MASONEILAN SVI1000 IN AREAS WHERE THERE IS A POTENTIAL FOR EXPLOSIVE GAS ATMOSPHERES



REV	Description	Date
A	Initial Release	Dec 15, 2010
B	ADR-003590	Oct 18, 2011
C	ADR-003639	Feb 7, 2012
D	ADR-003652	March 5, 2012
E	ADR-003853	Jun 03, 2013
F	ADR-004045	Dec 15, 2015
G	PDR ECO-0026891	Oct 28, 2016
H	PDR ECO-0033601	May 23, 2018

Written by	B. Belmarsh	Dec 15, 2010
Checked by	H. Smart	Dec 15, 2010
Approved by	M. Hebert	Dec 15, 2010

ES-761	Rev H
--------	-------

Copyright 2018 as an unpublished trade secret. This document and all information herein is the property of Dresser LLC. It is confidential and must not be made public or copied and is subject to return upon demand.



- 1 INTRODUCTION**
- 2 GENERAL REQUIREMENTS**
- 3 MODEL NUMBER DESCRIPTION OF SVI1000**
- 4 CLASSIFICATION SPECIFIC REQUIREMENTS**
  - 4.1 CLASS I DIVISION 2 (NON-INCENDIVE EQUIPMENT)
  - 4.2 GROUP II CATEGORY 1 (ZONE 0)
- 5 AGENCY MARKINGS**
  - 5.1 AGENCY MARKINGS
  - 5.2 OPERATING RANGES
  - 5.3 ENCLOSURE TYPE
  - 5.4 TEMPERATURE CODE
  - 5.5 NOTES RELATED TO INTRINSIC SAFETY
- 6 INTRINSICALLY SAFE INSTALLATION WIRING REQUIREMENTS**
  - 6.1 MODELS SVI1000ABC, WHERE A = SW OR NONE, INSTALLATION
  - 6.2 MODEL SVI1000ABC, WHERE A = PR INSTALLATION
- 7 NOTES FOR INTRINSICALLY SAFE INSTALLATION**
  - 7.1 HAZARDOUS LOCATION
  - 7.2 FIELD WIRING
  - 7.3 SVI1000 (+) AND (-) 4 TO 20MA INPUT TERMINALS
  - 7.4 SVI1000 (+) AND (-) SW OUTPUT TERMINALS
  - 7.5 SVI1000 (+) AND (-) POSITION RETRANSMIT (4-20MA OUTPUT) TERMINALS
  - 7.6 ENTITY REQUIREMENT
  - 7.7 INSTALLATION RESTRICTION
- 8 REPAIR**
- 9 MAINTENANCE CONNECTION**



## 1 Introduction

This document covers the requirements for safe installation, repair and operation of the SVi1000 as it relates to operation in areas where there is a potential for explosive gas atmosphere. Adherence to these requirements assures that the SVi1000 will not cause ignition of the surrounding atmosphere. Hazards related to control of the process are beyond the scope of this manual.

For mounting instructions on specific valves refer to the mounting instructions supplied with the mounting kit. Mounting does not affect the suitability of the SVi1000 for use in a potentially explosive gas atmosphere.

For language translation assistance contact your local representative or email [svisupport@ge.com](mailto:svisupport@ge.com).

Pour la langue de traduction aide, contactez votre représentant local ou envoyez un e-mail [svisupport@ge.com](mailto:svisupport@ge.com).

The SVi1000 positioner is manufactured by:

Dresser LLC  
12970 Normandy Blvd.  
Jacksonville FL 32221 USA

The SVi1000 is made in China.

---

Copyright 2018 as an unpublished trade secret. This document and all information herein is the property of Dresser LLC. It is confidential and must not be made public or copied and is subject to return upon demand.



## 2 General Requirements

**! WARNING!**

Failure to adhere to the requirements listed in this document may cause loss of life and property.

Installation and maintenance must be performed only by qualified personnel. Area Classification, Protection Type, Temperature Class, Gas Group, and Ingress protection must conform to the data indicated on the label.

Wiring and conduit must conform to all local and national codes governing the installation. Wiring must be rated for at least 5°C above the highest expected ambient temperature. **(ATTENTION – LE CABLAGE D’ALIMENTATION DOIT ETRE HOMOLOGUE POUR UNE TEMPERATURE SUPERIEURE D’AU MOINS 5°C A LA TEMPERATURE AMBIANTE MAXIMALE)**

Approved wire seals against ingress of water are required and the NPT fittings must be sealed with tape or thread sealant to meet the highest level of ingress protection.

Where the protection type depends on wiring glands, the glands must be certified for the type of protection required.

The metal housing is a die-cast alloy which is predominately aluminum.

“X” Marking on label - Since the SVi1000 enclosure contains greater than 10% aluminum; care must be taken during installation to avoid impacts or friction that could create an ignition source.

“X” Marking on label - Potential Electrostatic Charge Hazard – For safe operation use only wet cloth when cleaning or wiping device, and only when local conditions around the device are free of potentially explosive atmospheres. Do not use dry cloth. Do not use solvent.

Before powering the SVi1000:

- Verify that the cover screws are tightened. This is important to maintain the ingress protection level.
- If the installation is intrinsically safe, check that the proper barriers are installed and the field wiring meets local and national codes for an IS installation. Never install a device which was previously installed without an intrinsically safe barrier in an intrinsically safe system.
- If the pneumatic system is powered by a combustible gas then the installation must be treated as Zone 0 or DIV I.

---

Copyright 2018 as an unpublished trade secret. This document and all information herein is the property of Dresser LLC. It is confidential and must not be made public or copied and is subject to return upon demand.



- In non-incendive installations, check to ensure all electrical connections are made to approved circuits which meet local and jurisdictional installation codes.
- Verify that the markings on the label are consistent with the application.
- Verify that the air supply pressure cannot exceed the marking on the label.

### 3 Model Number Description of SVi1000

The SVi1000 model numbers approved for the use in potentially explosive atmospheres are shown in the following table. Model codes are:

SVi1000 abc

Where:

a = none, SW or PR

b = none or G

c = none or IM

MODEL	DESCRIPTION
SVi1000	SVi1000 Assembly
SVi1000 /SW	SVi1000 Assembly with switches
SVi1000 /G	SVi1000 Assembly with gauges
SVi1000 /SW/G	SVi1000 Assembly with switches and gauges
SVi1000 /IM	SVi1000 Assembly with integrated magnet
SVi1000 /G/IM	SVi1000 Assembly with gauges and integrated magnet
SVi1000 /SW/IM	SVi1000 Assembly with switches and integrated magnet
SVi1000 /SW/G/IM	SVi1000 Assembly with switches, gauges, and integrated magnet
SVi1000 /PR	SVi1000 Assembly with position retransmit
SVi1000 /PR/G	SVi1000 Assembly with position retransmit and gauges
SVi1000 /PR/IM	SVi1000 Assembly with position retransmit with integrated magnet
SVi1000 /PR/ G/IM	SVi1000 Assembly with position retransmit, gauges and integrated magnet

### 4 Classification Specific Requirements

#### 4.1 Class I Division 2 (Non-Incendive Equipment)

Explosion Hazard Warning: Do not disconnect equipment unless power has been switched off or the area is known to be non-hazardous.

#### 4.2 Group II Category 1 (Zone 0)

---

Copyright 2018 as an unpublished trade secret. This document and all information herein is the property of Dresser LLC. It is confidential and must not be made public or copied and is subject to return upon demand.



## GE Oil & Gas

For operation in hazardous area group II category 1, over voltage protection of the electrical connections need to be installed according to EN60079-14.

---

Copyright 2018 as an unpublished trade secret. This document and all information herein is the property of Dresser LLC. It is confidential and must not be made public or copied and is subject to return upon demand.



## 5 Agency Markings

### 5.1 Agency Markings

#### Factory Mutual Approvals

##### **Intrinsically Safe**

Class I Division 1 Groups A, B, C, D  
Class I Zone 0 AEx ia IIC Ga

##### **Non Incendive**

Class I Division 2 Groups A, B, C, D  
Class I Zone 2 AEx nC IIC T4 Gc

**Ingress Protection** NEMA 4X, IP66

#### Canada Approvals (FM Canada Approved)

(FM17CA0046X)

##### **Intrinsically Safe**

Class I Division 1 Groups A, B, C, D  
Class 1 Zone 0 Ex ia IIC T4 Ga

Class I Division 2 Groups A, B, C, D  
Class 1 Zone 2 Ex ic IIC T4 Gc

**Ingress Protection** Type 4X, IP66

#### ATEX Approvals

**FM 11ATEX0076X**

**FM 12ATEX0022X**

##### **Intrinsically Safe**

II 1G Ex ia IIC T4 Ga  
II 3G Ex ic IIC T4 Gc

**Ingress Protection** IP 66

#### IECEX Approvals

**IECEX FMG 11.0033X**

##### **Intrinsically Safe**

Ex ia IIC T4 Ga  
Ex ic IIC T4 Gc

**Ingress Protection:** IP 66



##### **Temperature Classification**

T4 Ta=-40°C to 85°C  
T4 Ta=-40°C to 85°C

##### **Temperature Classification**

T4 Ta=-40°C to 85°C  
T4 Ta=-40°C to 85°C



##### **Temperature Classification**

T4 Ta=-40°C to 85°C  
T4 Ta=-40°C to 85°C

##### **Temperature Classification**

T4 Ta=-40°C to 85°C  
T4 Ta=-40°C to 85°C



##### **Temperature Classification**

T4 Ta= -40°C to 85°C  
T4 Ta= -40°C to 85°C

##### **Temperature Classification**

T4 Ta= -40°C to 85°C  
T4 Ta= -40°C to 85°C

Copyright 2018 as an unpublished trade secret. This document and all information herein is the property of Dresser LLC. It is confidential and must not be made public or copied and is subject to return upon demand.



## 5.2 Operating Ranges

### 5.2.1 Temperature

-40°C to 85°C

### 5.2.2 Input Voltage

30 volts

### 5.2.3 Supply Pressure

100 psig

Clean instrument air and natural gas are the typical supply sources.

### 5.2.4 Current

4 to 20mA

## 5.3 Enclosure Type

NEMA 4X

Type 4X

IP66

## 5.4 Temperature Code

T4 Ta=85°C

## 5.5 Notes Related to Intrinsic Safety

1. "Intrinsically safe when installed per ES-761"
2. "Supply connection wiring rated for 5°C above maximum ambient temperature"
3. Permanently mark the label for the protection type chosen. Once the type has been marked, it cannot be changed.
4. It must be ensured the thermal effect of the process temperature does not result in exceeding the SVi1000 specified ambient temperature of -40°C to 85°C.

---

Copyright 2018 as an unpublished trade secret. This document and all information herein is the property of Dresser LLC. It is confidential and must not be made public or copied and is subject to return upon demand.





## 6 Intrinsically Safe Installation Wiring Requirements

Each intrinsically safe cable must include a grounded shield or be run in a separate metal conduit.

### 6.1 Models SVi1000abc, where a = SW or none, Installation

HAZARDOUS LOCATION  
SEE NOTES 7.1 AND 7.2

NON-HAZARDOUS LOCATION - UNSPECIFIED EXCEPT THAT BARRIERS MUST NOT BE SUPPLIED FROM NOR CONTAIN UNDER NORMAL OR ABNORMAL CONDITIONS A SOURCE OF POTENTIAL WITH RESPECT TO EARTH IN EXCESS OF 250 VOLTS RMS OR 250 VOLTS DC

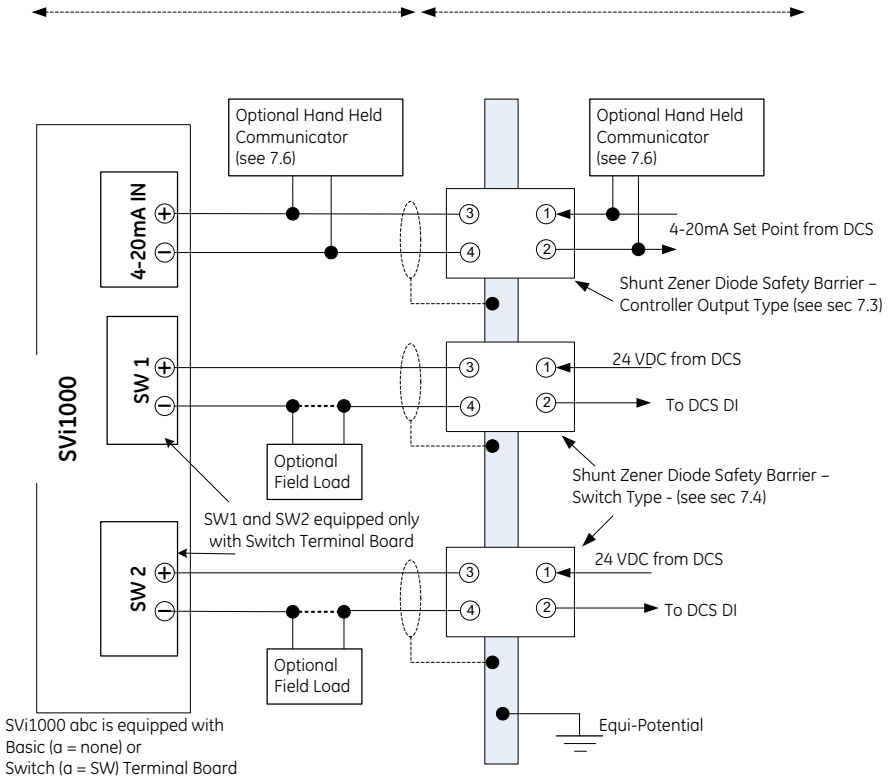

Copyright 2018 as an unpublished trade secret. This document and all information herein is the property of Dresser LLC. It is confidential and must not be made public or copied and is subject to return upon demand.



6.2 Model SVi1000abc, where a = PR Installation

HAZARDOUS LOCATION  
SEE NOTES 7.1 AND 7.2

NON-HAZARDOUS LOCATION – UNSPECIFIED EXCEPT THAT BARRIERS MUST NOT BE SUPPLIED FROM NOR CONTAIN UNDER NORMAL OR ABNORMAL CONDITIONS A SOURCE OF POTENTIAL WITH RESPECT TO EARTH IN EXCESS OF 250 VOLTS RMS OR 250 VOLTS DC

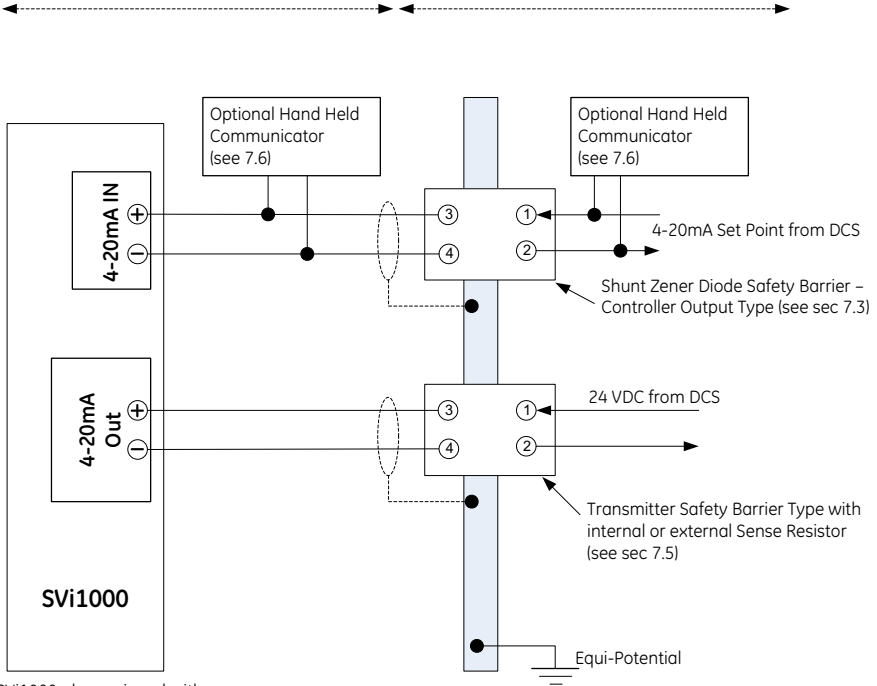

SVi1000 abc equipped with Position Retransmit Terminal Board (a = PR)

Copyright 2018 as an unpublished trade secret. This document and all information herein is the property of Dresser LLC. It is confidential and must not be made public or copied and is subject to return upon demand.



## 7 Notes for Intrinsically Safe Installation

### 7.1 Hazardous Location

Refer to the device label for the description of the environment in which the device may be installed.

### 7.2 Field Wiring

Intrinsically Safe wiring must be made with grounded shielded cable or installed in grounded metal conduit. **(CHAQUE CABLE A SECURITE INTRINSEQUE DOIT INCLURE UN BLINDAGE MIS A LA TERRE OU DOIT FONCTIONNER DANS UN CONDUIT EN METAL SEPRE)** The electrical circuit in the hazardous area must be capable of withstanding an A.C. test voltage of 500 volts R.M.S. to earth or frame of the apparatus for 1 minute. Installation must be in accordance with GE guidelines. The installation including the barrier earthing requirements must comply with the installation requirements of the country of use.

Factory Mutual requirements (USA): ANSI/ISA RP12.6 (Installation of Intrinsically Safe Systems for Hazardous (Classified) Locations) and the National Electrical Code, ANSI/NFPA 70. Division 2 installations must be installed per the National Electrical Code, ANSI/NFPA 70.

CSA requirements (Canada): Canadian Electrical Code Part 1. Division 2 installations must be installed per the Canadian Electrical Code Division 2 Wiring Methods.

ATEX requirements (EU): Intrinsically safe installations must be installed per EN60079-10 and EN60079-14 as they apply to the specific category.

### 7.3 SVi1000 (+) and (-) 4 to 20mA Input Terminals

These terminals power the SVi1000 and are equipped on the Basic, Switch and Position Retransmit Terminal boards.

Entity Parameters:

$V_{max} = 30 \text{ Vdc}$

$I_{max} = 125 \text{ mA}$

$P_{max} = 900 \text{ mW}$

$C_i = 6.5 \text{ nF}$

$L_i = 1 \text{ uH}$

### 7.4 SVi1000 (+) and (-) SW Output Terminals

There are two independent isolated solid state switch contact outputs on the SVi1000. They are labeled SW#1 and SW#2. The switches are polarity sensitive (conventional current flows into the plus terminal). These terminals are equipped only on the Switch Terminal board.

Entity parameters are:

$V_{max} = 30 \text{ Vdc}$

---

Copyright 2018 as an unpublished trade secret. This document and all information herein is the property of Dresser LLC. It is confidential and must not be made public or copied and is subject to return upon demand.



$I_{max}=125$  mA  
 $P_{max} = 900$  mW  
 $C_i = 4$  nF  
 $L_i = 10$  uH

## 7.5 SVi1000 (+) and (-) Position Retransmit (4-20mA Output) Terminals

These terminal provide the 4-20mA position retransmit output and are equipped only on the Position Retransmit Terminal board. A transmitter type barrier with 250 Ohm series resistance (internal or external) could be used for this connection.

Entity Parameters:

$V_{max}= 30$  Vdc  
 $I_{max}=125$  mA  
 $P_{max} = 900$  mW  
 $C_i = 8$  nF  
 $L_i = 1$  uH

## 7.6 Entity Requirement

Cable capacitance and inductance plus the I.S. apparatus unprotected capacitance ( $C_i$ ) and inductance ( $L_i$ ) must not exceed the allowed capacitance ( $C_a$ ) and inductance ( $L_a$ ) indicated on the associated apparatus. If the optional Hand Held Communicator is used on the Hazardous Area side of the barrier, then the capacity and inductance of the communicator must be added and the communicator must be agency approved for use in the hazardous area. Also, the current output of the Hand Held Communicator must be included in the current output of the associated equipment.

The barriers may be active or passive and from any certified manufacturer as long as the barriers comply with the listed entity parameters.

## 7.7 Installation Restriction

A device which has previously been installed without an approved IS barrier must NEVER be used subsequently in an intrinsically safe system. Installing the device without a barrier can permanently damage the safety related components in the device making the device unsuitable for use in an intrinsically system.

## 8 Repair

WARNING: EXPLOSION HAZARD – SUBSTITUTION OF COMPONENTS MAY IMPAIR SUITABILITY FOR USE IN A HAZARDOUS LOCATION.

Only qualified service personnel are permitted to make repairs on the SVi1000 positioner. Replace ONLY with genuine GE parts.

---

Copyright 2018 as an unpublished trade secret. This document and all information herein is the property of Dresser LLC. It is confidential and must not be made public or copied and is subject to return upon demand.



Replacement of the Main electronics board, Basic, Switch and Position Retransmit Terminal boards, Housing cover kit, pressure gauges, I/P assembly and Integral magnet assembly are the only field repairs permitted.

Upon completion of part replacement, ensure all retaining screws are securely tightened, all "O" rings are in place and not damaged, and all wires are securely connected.

When installing the main cover ensure the gasket is seated in the cover flange groove, the flange area is not corroded and the surface is not scarred and that no wires can be trapped under the cover flange. Ensure the four cover bolts screws are secure by applying  $17.7 \pm 1.77$  in-lbs or  $2.0 \pm 0.20$  N\*m.

For assistance, contact the nearest sales office, your local representative or email [svisupport@ge.com](mailto:svisupport@ge.com). Visit our web page at [www.ge-energy.com/valves](http://www.ge-energy.com/valves)

## 9 Maintenance Connection

The electronics module is protected by a plastic snap on cover. A keyed eight position connector resides under the cover. This interface is only used during manufacturing, repair or overhaul. It is not intended for field use and has been designed to prevent connection to field wiring. It is not intended for customer use.

*This page intentionally left blank.*



## DIRECT SALES OFFICE LOCATIONS

### AUSTRALIA

Brisbane  
Phone: +61-7-3001-4319  
Fax: +61-7-3001-4399

### Perth

Phone: +61-8-6595-7018  
Fax: +61-8-6595-7299

### Melbourne

Phone: +61-3-8807-6002  
Fax: +61-3-8807-6577

### BELGIUM

Phone: +32-2-344-0970  
Fax: +32-2-344-1123

### BRAZIL

Phone: +55-19-2104-6900

### CHINA

Phone: +86-10-5738-8888  
Fax: +86-10-5918-9707

### FRANCE

Courbevoie  
Phone: +33-1-4904-9000  
Fax: +33-1-4904-9010

### GERMANY

Ratingen  
Phone: +49-2102-108-0  
Fax: +49-2102-108-111

### INDIA

Mumbai  
Phone: +91-22-8354790  
Fax: +91-22-8354791

### New Delhi

Phone: +91-11-2-6164175  
Fax: +91-11-5-1659635

### ITALY

Phone: +39-081-7892-111  
Fax: +39-081-7892-208

### JAPAN

Tokyo  
Phone: +81-43-297-9222  
Fax: +81-03-299-1115

### KOREA

Phone: +82-2-2274-0748  
Fax: +82-2-2274-0794

### MALAYSIA

Phone: +60-3-2161-0322  
Fax: +60-3-2163-6312

### MEXICO

Phone: +52-55-3640-5060

### THE NETHERLANDS

Phone: +31-15-3808666

### RUSSIA

Veliky Novgorod  
Phone: +7-8162-55-7898  
Fax: +7-8162-55-7921

### Moscow

Phone: +7 495-585-1276  
Fax: +7 495-585-1279

### SAUDI ARABIA

Phone: +966-3-341-0278  
Fax: +966-3-341-7624

### SINGAPORE

Phone: +65-6861-6100  
Fax: +65-6861-7172

### SOUTH AFRICA

Phone: +27-11-452-1550  
Fax: +27-11-452-6542

### SOUTH and CENTRAL AMERICA AND THE CARIBBEAN

Phone: +55-12-2134-1201  
Fax: +55-12-2134-1238

### SPAIN

Phone: +34-93-652-6430  
Fax: +34-93-652-6444

### UNITED ARAB EMIRATES

Phone: +971-4-8991-777  
Fax: +971-4-8991-778

### UNITED KINGDOM

Bracknell  
Phone: +44-1344-460-500  
Fax: +44-1344-460-537

### UNITED STATES

Jacksonville, Florida  
Phone: +1-904-570-3409

### Deer Park, Texas

Phone: +1-281-884-1000  
Fax: +1-281-884-1010

### Houston, Texas

Phone: +1-281-671-1640  
Fax: +1-281-671-1735

[valves.bhge.com](http://valves.bhge.com)

\*Denotes a registered trademark of the Baker Hughes, a GE company LLC. Other company names and product names used in this document are the registered trademarks or trademarks of their respective owners.

© 2019 Baker Hughes, a GE company, LLC. - All rights reserved.

Baker Hughes, a GE company, LLC and its affiliates ("BHGE") provides this information on an "as is" basis for general information purposes and believes it to be accurate as of the date of publication. BHGE does not make any representation as to the accuracy or completeness of the information and makes no warranties of any kind, specific, implied or oral, to the fullest extent permissible by law, including those of merchantability and fitness for a particular purpose or use. BHGE hereby disclaims any and all liability for any direct, indirect, consequential or special damages, claims for lost profits, or third party claims arising from the use of the information, whether a claim is asserted in contract, tort, or otherwise. Baker Hughes, a GE company and the GE monogram are trademarks of the General Electric Company. Denotes a trademark of the General Electric Company.

**BAKER  
HUGHES**  
a GE company

