

# Masoneilan™ 72000 Series Control Valve

Large Mass Flow Energy  
Management Control Valves



# Table of Contents

Introduction.....	3
Product Features.....	3
General Data .....	5
Numbering System.....	6
Temperature Range/Seat Leakage.....	6
Rated $C_v$ Table.....	7
General Arrangement and Parts Description.....	8
Hydrocarbon Service Material Options.....	10
Steam Service Material Options .....	11
Selection Instructions.....	12
Typical Dimensions .....	12
Approximate Shipping Weights .....	13
Accessories and Options.....	13

# Introduction

Masoneilan's 72000 Series energy management and low noise products by Baker Hughes are specifically designed for applications with large mass flow rates and high differential pressures. Typical installations may be found in compressor surge control, gas to flare, atmospheric vent, or other applications where the ratio of inlet/outlet pressures require substantial levels of noise attenuation and large valve sizes. A variety of options and configurations are available to create effective solutions for our customers' specific applications.

The 72000 Series is a valve solution engineered to meet a client's need. As such, the exact product configuration may differ from the general specifications, dependent upon the application. For additional information, contact your local Baker Hughes Sales representative.

The 72000 Series Control Valve may be custom engineered to fit an application. The data within this catalog is representative of typical configurations and does not include all potential design options.

## Product Features

### Engineered – Best Fit – Solutions

At Baker Hughes, we believe our customers deserve the Best Fit solution for their severe service valve applications. Our broad product portfolio and valve trim technologies allow an uncompromising approach in addressing a client's need, and therefore, each 72000 Series valve is engineered to meet a customer's exact specifications and application conditions. This allows us to offer the most technically advanced and cost-effective solution to your energy management and noise control applications.

### Low Noise Trim

Our Best Fit approach allows for the widest range of noise attenuation options, providing the desired noise level at the lowest cost of ownership. These attenuation products range from single and double stage *Lo-dB™* trim or up to as many as 40 stages of 3-dimensional *V-LOG™* tortuous path trim. The selected trim option is always custom engineered to provide best results for each unique application.

Single and double stage *Lo-dB* trim is selected in most low to moderate pressure drop ratio applications. This technology is customized by modifying the size and spacing of each hole drilled into the cage to provide a minimal sound pressure level at the trim exit.

The 3-dimensional tortuous path design of Masoneilan's *V-LOG* trim controls pressure reduction through the management of the process fluid energy. This is accomplished by directing the gas through discrete flow channels that are designed with multiple stages consisting of 90-degree turns along with the intermediate contractions and expansions in the flow area. The enhanced flow geometry of the *V-LOG* trim creates a series of kinetic energy losses, followed by partial energy recoveries at each stage. This gradual letdown process is highly effective for noise attenuation due to the staged reduction of the fluid's pressure.

### Large Pressure Drop – Energy Management

Process applications that require the 72000 Series design often experience extremely high pressure drop ratios ( $P1/P2$ ). These high ratios release large amounts of energy as the process fluid's pressure is reduced. This energy release can lead to excessive noise and vibration if not properly addressed in the valve design.

The 3-dimensional tortuous path design of Masoneilan's *V-LOG* Trim controls pressure reduction through the management of process fluid energy. This is accomplished by directing the gas through discrete flow channels.

The labyrinth flow path of the *V-LOG* Trim subjects the gas to a high level of friction as it is redirected through each turn in the flow path. *V-LOG*'s patented flow contractions produce maximum flow resistance.

The enhanced flow geometry of the *V-LOG* trim creates a series of kinetic energy losses, followed by partial energy recoveries at each state. This gradual letdown process is highly effective for noise attenuation due to the staged reduction of the fluid pressure.

Each stage of the *V-LOG* trim is designed with an expansion in flow area, which is essential for managing fluid velocity that would otherwise increase as the pressure is reduced across each stage. The expanding area is designed to compensate for the volumetric expansion of the gas, preventing any increase in the kinetic energy as the pressure is reduced.

Trim velocity control is important for maintaining low aerodynamic noise levels within the valve body and trim. High velocity trim exit flow will yield high magnitude sound waves, which lead to valve body vibration in high-pressure letdown applications.

As a gas experiences a large reduction in pressure, the volume of the gas expands. This phenomenon will yield a higher downstream velocity if the piping is designed without considering this volumetric expansion.

# Product Features (cont.)

Masoneilan's 72000 Series is designed with expanded outlet areas to accommodate this expansion, and minimize the overall system noise level.

*Note: Baker Hughes considers both outlet mach number and the outlet expansion ratio for system noise calculation, per the IEC International Noise Predication Standard (IEC-60534-8-3).*

## High Capacity

Baker Hughes has developed flexible, automated design tools for the 72000 Series line, allowing "ground up" fabrication of custom engineered valve solutions in very short lead times. High capacities and custom  $C_v$ s are met through a wide range of valve plug diameters, stroke lengths, and body gallery diameters to suit any application within standard product lead times.

## Balanced Plug

Balanced plug designs deliver stability with smaller actuator thrust requirements, as compared to unbalanced designs. Normally, the 72000 Series valves are installed in a flow-to-open configuration allowing radial expansion from the smaller diameter cage to the expanded area of the valve body. The free expansion of the fluid and precise separation of the trim exit flow jets, maximize trim noise attenuation and minimizes vibration within the valve body. For installations that require flow-to-close configurations, an auxiliary pilot plug may be supplied to reduce actuator thrust requirements.

## Ease of Maintenance

Top entry trim allows easy access to the valve internals for lower life cycle costs and easier maintenance activity. Baker Hughes provides ample padeyes and tapped holes for standard lifting and handling equipment, eliminating the need for special fixtures or tooling. All trim components are cage guided, with ample clearance at the body, bonnet, and bridge regions for ease of removal and replacement. The 72000 Series design employs a minimum number of gaskets and soft goods, making outage planning and stocking requirements easier.

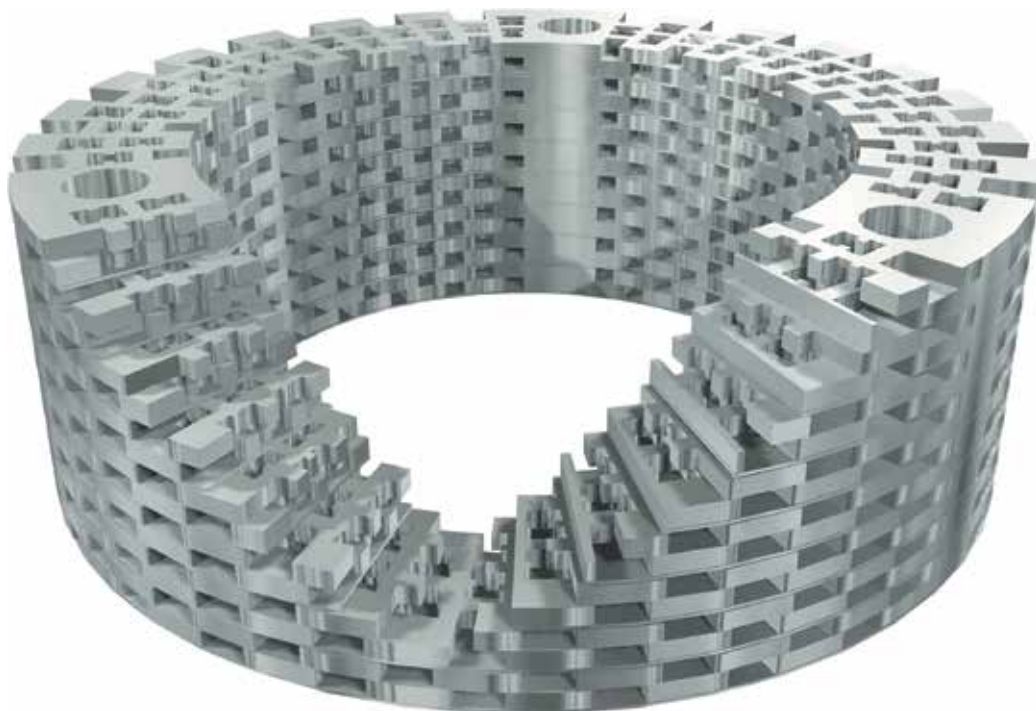

# General Data

## Operating Data

### Flow Direction

Flow to Open (Standard)  
Flow to Close (Auxiliary Pilot Plug Option Only)

### Flow Direction

Flow-to-Open (Standard)  
Flow-to-Close (Optional)

### Construction

Body, Bonnet & Bonnet Flange; Fabricated or Cast

Styles: Angle (Figures 1, 2, and 3)

Materials: Body  
Carbon Steel  
Low Temperature Carbon Steel  
316 Stainless Steel  
Chrome Moly Steels  
Other materials available on request

Sizes: Inlet 4" – 30" (DN 100–750)  
Outlet 6" – 36" (DN 150–900)  
Larger sizes available on request

Connections: End Types  
ASME Flanges  
Printed or Through Bolted  
RTJ Flanges  
Printed or Through Bolted  
Buttweld  
API

Pressure Rating: Inlet Ratings: ASME Class 150# – 2500#  
Outlet Ratings: ASME Class 150# – 600#  
Others available upon request

## Trim

Plug: Balanced  
Unbalanced  
Auxiliary Pilot

Cage or Stack: Ported Cage  
Single Stage Lo-dB  
Double Stage Lo-dB  
V-LOG Stack  
Partial Stack

Seat Ring: Quick Change

# Numbering System

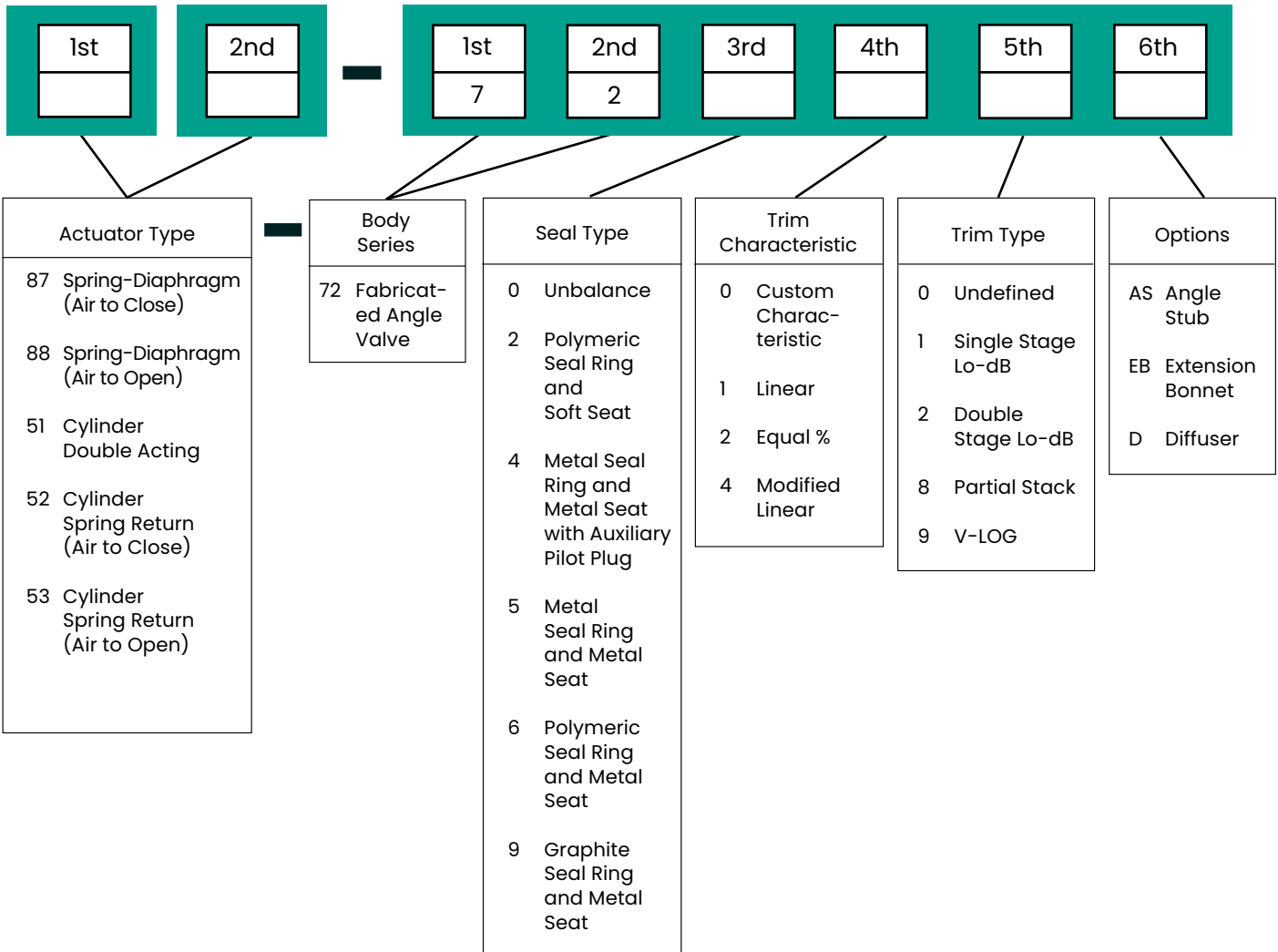

# Temperature Range/Seat Leakage

Seal Ring	Seat Ring	Leakage Class	Temperature Ranges <sup>1</sup>	
			Min.	Max.
Unbalance	Metal	Class V MSS-SP-61	-320°F (-196°C)	1100°F (594°C)
Polymeric (Pressure Energized)	Filled PTFE	Class IV, V, VI	-50°F (-46°C)	450°F (232°C)
Pilot Plug	Metal	Class V	-320°F (-196°C)	1100°F (594°C)
Metal	Metal	Class III	-320°F (-196°C)	1100°F (594°C)
Polymeric (Pressure Energized)	Metal	Class IV,V MSS-SP-61	-50°F (-46°C)	450°F (232°C)
Graphite	Metal	Class III,IV	-320°F (-196°C)	850°F (454°C)

1. Cryogenic and high temp construction available, consult factory.

# Flow Capacity

## Rated $C_v$

Approximate  $C_v$  values are intended for estimation only. The actual  $C_v$  values will vary depending on the number of turns, stroke length, and resistance factor of each valve design. The specific  $C_v$  values will be determined by a Baker Hughes engineer.

Size (Inch)	V-LOG # of Turns				Single Stage Lo-dB	Double Stage Lo-dB
	8	16	24	36		
4 x 6	100	70	38	25	200	110
4 x 8	140	98	53	35	265	140
4 x 10	175	125	66	44	300	165
6 x 6	220	154	84	55	320	175
6 x 8	275	192	105	68	425	225
6 x 10	325	230	125	80	500	275
8 x 8	450	315	170	112	575	310
8 x 10	525	368	200	130	650	350
8 x 12	550	385	210	138	900	500
10 x 10	600	420	230	150	850	475
10 x 16	660	462	250	165	1000	550
10 x 18	700	490	266	175	1200	680
10 x 20	730	510	278	182	1750	970
12 x 12	1050	735	400	260	1100	600
12 x 16	1200	840	460	300	1200	680
12 x 18	1280	900	485	320	1350	720
12 x 20	1320	920	500	330	1600	880
12 x 24	1350	945	510	338	2250	1250
16 x 16	1400	980	532	350	1750	950
16 x 20	1525	1065	580	380	2250	1250
16 x 24	1600	1120	608	400	2800	1520
16 x 30	1650	1155	627	410	3500	1930
20 x 20	1600	1120	610	400	2500	1380
20 x 24	1800	1260	685	450	2750	1520
20 x 30	1950	1365	740	485	3700	2000
20 x 36	2100	1470	800	525	5000	2750
24 x 24	2150	1500	820	540	3500	1930
24 x 30	2400	1680	910	600	4500	2500
24 x 36	2500	1750	950	625	6400	3500
30 x 30	3000	2100	1140	750	9400	5000
30 x 36	3600	2520	1370	900	13500	7000

These values represent typical construction. Larger or reduced capacity available upon request, consult factory.

## Minimum Controllable $C_v$

Plug (Inch)	V-LOG # of Turns				Single Stage Lo-dB	Double Stage Lo-dB
	8	16	24	36		
4	2	1.5	0.8	0.6	4	3
6	4	3	2.5	2.2	8	7
8	6	5	3.6	3	15	12
10	9	6	4.7	4	30	25
12	15	12	9	7	40	35
16	20	14	11	8	70	60
20	25	18	14	11	90	75
24	40	26	20	14	120	105
30	60	40	25	18	250	215

# General Arrangement and Parts Description

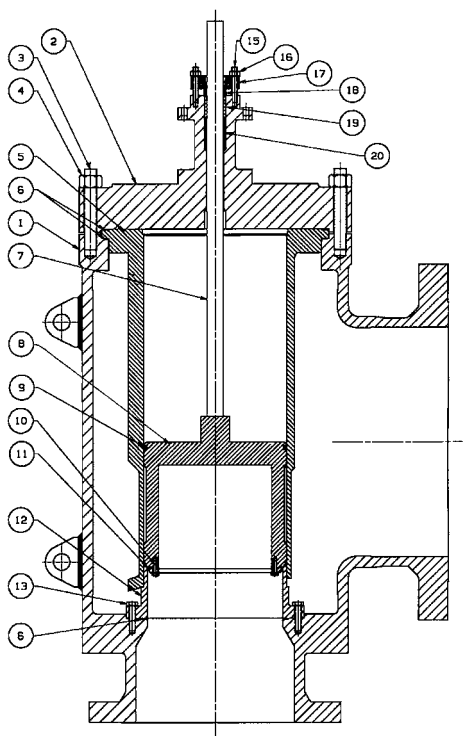

**Figure 1 – Hung Cage Construction**

Ref. No.	Description
1	Body
2	Bonnet
3	Bonnet Stud
4	Body Nut
5	Hung Cage
•6	Gasket
7	Stem
8	Plug
9	Seal Ring
10	Cap Screw
11	Soft Seat
12	Seat Ring
13	Seat Ring Cap Screw
15	Packing Flange Stud
16	Packing Flange Nut
17	Packing Flange
18	Packing Follower
•19	Packing S/A
20	Guide Bushing

• Recommended Spare Parts

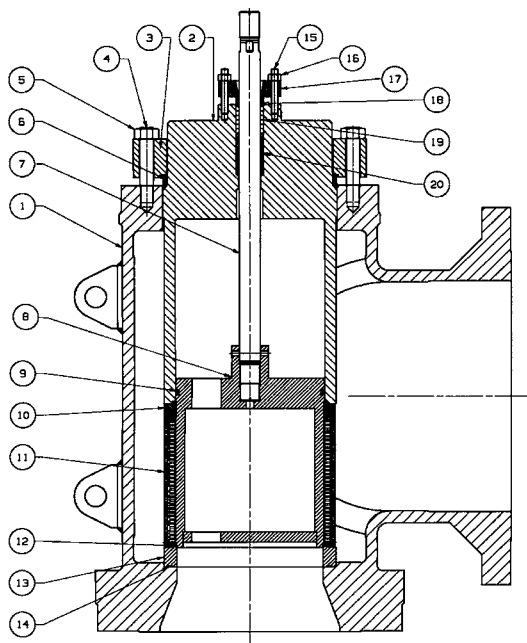

**Figure 2 – High Pressure, Lo-dB  
(Double Stage Option Shown)**

Ref. No.	Description
1	Body
2	Bonnet
3	Bonnet Flange
4	Body Stud
5	Body Nut
6	Metal Seal
7	Stem
8	Plug
9	Seal Ring
10	Inner Cage
11	Outer Cage
12	Soft Seat
13	Seat Ring
•14	Gasket
15	Packing Flange Stud
16	Packing Flange Nut
17	Packing Flange
18	Packing Follower
•19	Packing S/A
20	Guide Bushing

• Recommended Spare Parts



# General Arrangement and Parts Description

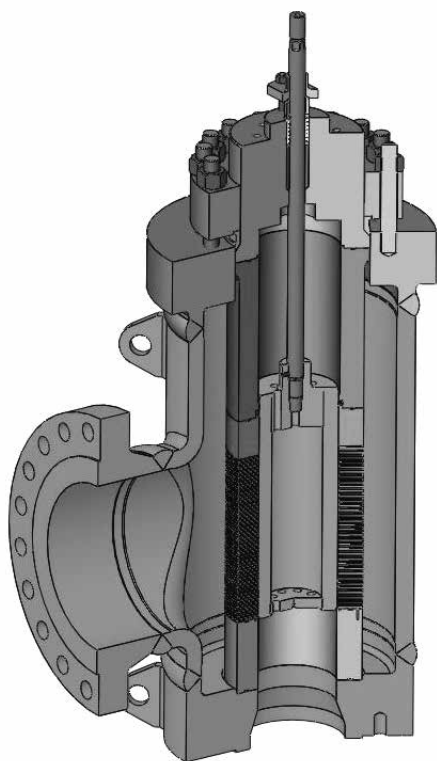

Cut Away View of Angle Style Valve with V-LOG Trim

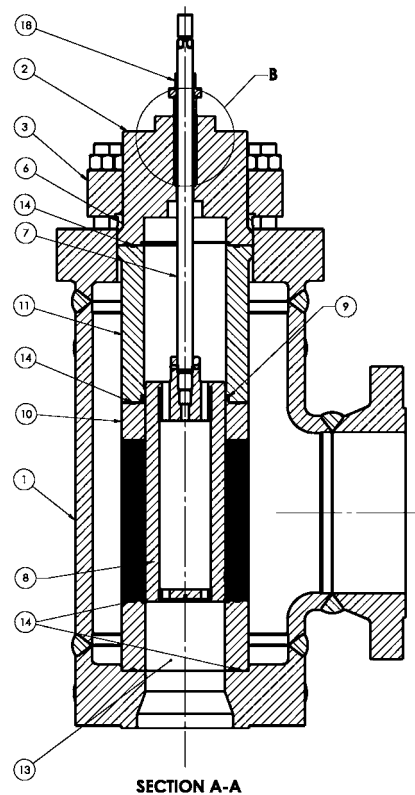

SECTION A-A

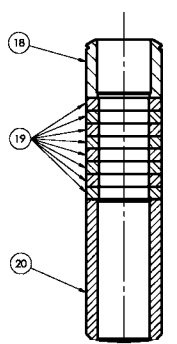
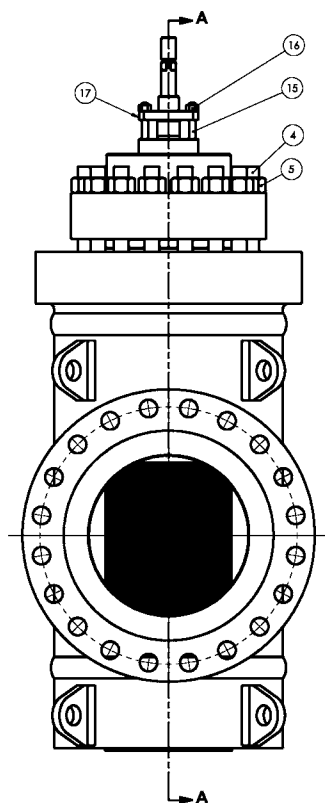

DETAIL B  
SCALE 1 : 1.5

Ref. No.	Description
1	Body
2	Bonnet
3	Bonnet Flange
4	Body Stud
5	Body Nut
6	Metal Seal
7	Stem
8	Plug
9	Seal Ring S/A
10	V-Log Restrictor
11	Cage Retainer
13	Seat Ring
•14	Gasket
15	Packing Flange Stud
16	Packing Flange Nut
17	Packing Flange
18	Packing Follower
•19	Packing S/A
20	Guide Bushing

• Recommended Spare Parts

Figure 3 – V-LOG Construction

# Hydrocarbon Service Material Options

Ref. No.	Temperature Range	-20°F -29°C	-450°F -232°C	650°F -343°C
	Description	Standard and Optional Materials		
1	Body	Carbon Steel		
		300 Series Stainless Steel		
2	Bonnet	Carbon Steel		
		300 Series Stainless Steel		
3	Bonnet Flange	Carbon Steel		
		300 Series Stainless Steel		
4	Body Stud	Alloy Steel ASTM A193 Gr B7 <sup>1</sup>		
		Alloy Steel ASTM A193 Gr B7M <sup>2</sup>		
5	Body Nut	Alloy Steel ASTM A194 Gr 2H <sup>1</sup>		
		Alloy Steel ASTM A194 Gr 2HM <sup>2</sup>		
6	Metal Seal	Alloy Steel		
7	Stem	17-4 PH Condition H-1150M <sup>3</sup>		
		Nitronic <sup>®</sup> 50 <sup>3</sup>		
8	Plug	316 Stainless Steel / Chrome Plated and Hardfaced <sup>3</sup>		
9	Seal Ring Sub-Assembly	PTFE + 25% Graphite and ELGILOY <sup>®</sup> Spring	Graphite	
10	Cage	316 Stainless Steel <sup>3</sup>		
11	Cage Retainer	316 Stainless Steel <sup>3</sup>		
13	Seat Ring	316 Stainless Steel with Hardfaced Seat <sup>3</sup>		
14	Gasket	316 Stainless Steel with Flexible Graphite Filler (Spiral Wound)		
15	Packing Flange Stud	304 Stainless Steel ASTM A193 Gr B8 Class 2 <sup>1</sup>		
		Alloy Steel ASTM A193 Gr B7M <sup>2</sup>		
16	Packing Flange Nut	304 Stainless Steel ASTM A194 Gr 8 <sup>1</sup>		
		Alloy Steel ASTM A194 Gr 2HM <sup>2</sup>		
17	Packing Flange	300 Series Stainless Steel		
18	Packing Follower	300 Series Stainless Steel		
19	Packing Sub-Assembly	Teflon <sup>®</sup> V-Ring	Flexible Graphite	
20	Guide Bushing	RTFE	Stellite <sup>®</sup> 6 UNS 30006	

1. Materials designated for these parts conform to NACE MR0103 Class III bolting requirements.

2. Materials designated for these parts conform to NACE MR0103 Class I or Class II bolting requirements.

3. Materials and processes in accordance with the requirements of NACE MR0103. Applications requiring compliance to NACE MR0175 - 2003 or ISO 15156 must be reviewed by Baker Hughes.

# Materials of Construction

Ref. No.	Temperature Range	-20°F -29°C	-650°F -343°C	-800°F -426°C	-950°F -510°C	-1100°F -593°C	
		Standard and Optional Materials					
1	Body	Carbon Steel			Chromoly Steel		
		Carbon Steel			Chromoly Steel		
2	Bonnet	Carbon Steel			Chromoly Steel		
		Carbon Steel			Chromoly Steel		
3	Bonnet Flange	Carbon Steel			Chromoly Steel		
		Carbon Steel			Chromoly Steel		
4	Body Stud	Alloy Steel ASTM A193 Gr B7			316 St. St. ASTM A193 Gr B16	Super Alloy ASTM A453 Grade 660	
5	Body Nut	Alloy Steel ASTM A194 Gr 2H			Carbon Steel Alloy Steel ASTM A194 Gr 4	304 St. St. ASTM A194 Gr 8	
6	Metal Seal	Alloy Steel					
7	Stem	17-4 PH Condition H-II50M		Inconel® X-750			
8	Plug	316 Stainless Steel / Chrome Plated and Hardfaced			420 Stainless Steel		
					4130 Alloy Steel		
9	Seal Ring Sub-Assembly	PTFE + 25% Graphite and ELGILOY Spring		Graphite			
				Nitrided CA6NM			
10	Cage	316 Stainless Steel			410 Stainless Steel		
					Inconel 718		
11	Cage Retainer	316 Stainless Steel			410 Stainless Steel		
13	Seat Ring	316 Stainless Steel with Hardfaced Seat			416 Stainless Steel		
14	Gasket	316 Stainless Steel with Flexible Graphite Filler (Spiral Wound)			Inconel with Graphite (Spiral Wound)		
15	Packing Flange Stud	304 Stainless Steel ASTM A193 Gr B8 Class 2					
16	Packing Flange Nut	304 Stainless Steel ASTM A194 Gr 8					
17	Packing Flange	300 Series Stainless Steel					
18	Packing Follower	300 Series Stainless Steel					
19	Packing Sub-Assembly	Teflon V-Ring			Flexible Graphite		
20	Guide Bushing	RTFE			Stellite 6 UNS 30006		

1. The materials listed above are for standard configurations.
2. Specific applications may require material changes for optimum performance.
3. Consult factory for applications above 800°F or where large thermal transients exist.

# Selection Instructions

Specifying an energy management or low noise product involves sound engineering judgment and application understanding. Baker Hughes has developed a computer-based valve sizing and selection program to aid our application specialists in choosing the correct

product. Each 72000 Series valve is specified with the Best Fit number of turn or stages according to the noise requirements and pressure drop ratio. Please contact your local Baker Hughes representative for application assistance.

## Typical Dimensions

### Approximate Body Dimensions

Approximate dimensions for 72000 Series valve are intended for estimating purposes only. Dimensions for a specific design can be provided by the factory upon request.

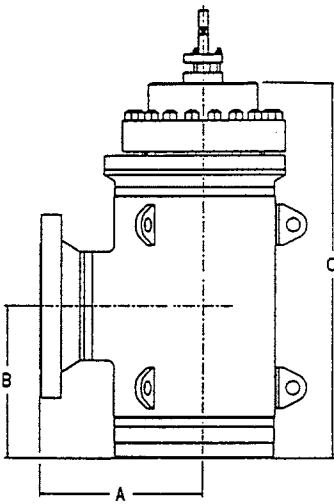

Size (Inch)	Dimension for ASME 300# (Inch)		
	A	B	C
4 x 6	13	11	24
4 x 8	14	12	25
4 x 10	15	13	26
6 x 6	14	12	28
6 x 8	14	12	29
6 x 10	15	13	31
8 x 8	16	13	33
8 x 10	16	13	34
8 x 12	18	14	35
10 x 10	19	16	36
10 x 16	19	18	38
10 x 18	21	20	39
10 x 20	21	26	42
12 x 12	21	30	42
12 x 16	22	31	44
12 x 18	22	32	45
12 x 20	23	32	46
12 x 24	24	32	50
16 x 16	27	32	50
16 x 20	27	33	52
16 x 24	28	34	56
16 x 30	30	34	60
20 x 20	32	34	64
20 x 24	32	35	68
20 x 30	34	36	68
20 x 36	36	39	70
24 x 24	38	40	70
24 x 30	38	40	70
24 x 36	40	43	71
30 x 30	42	44	72
30 x 36	44	45	75

Size (Inch)	Dimension for ASME 300# (mm)		
	A	B	C
4 x 6	330	279	610
4 x 8	356	305	635
4 x 10	381	330	660
6 x 6	356	305	711
6 x 8	356	305	737
6 x 10	381	330	787
8 x 8	406	330	838
8 x 10	406	330	864
8 x 12	457	356	889
10 x 10	483	406	914
10 x 16	483	457	965
10 x 18	533	508	991
10 x 20	533	660	1067
12 x 12	533	762	1067
12 x 16	559	787	1118
12 x 18	559	813	1143
12 x 20	584	813	1168
12 x 24	610	813	1270
16 x 16	686	813	1270
16 x 20	686	838	1321
16 x 24	711	864	1422
16 x 30	762	864	1524
20 x 20	813	864	1626
20 x 24	813	889	1727
20 x 30	864	914	1727
20 x 36	914	991	1778
24 x 24	965	1016	1778
24 x 30	965	1016	1778
24 x 36	1016	1092	1803
30 x 30	1067	1118	1892
30 x 36	1118	1143	1905

# Approximate Shipping Weights

Approximate shipping weights are intended for estimating purposes. Weights for a specific design can be provided by the factory upon request.

Size (Inch)	Weight for ASME 300# (lbs)	Size (Inch)	Weight for ASME 300# (lbs)	Size (Inch)	Weight for ASME 300# (lbs)
4 x 6	1,000	10 x 18	3,500	20 x 20	11,250
4 x 8	1,100	10 x 20	3,800	20 x 24	12,500
4 x 10	1,250	12 x 12	4,000	20 x 30	14,000
6 x 6	1,100	12 x 16	4,200	20 x 36	15,000
6 x 8	1,200	12 x 18	4,500	24 x 24	13,000
6 x 10	1,400	12 x 20	5,000	24 x 30	14,500
8 x 8	1,600	12 x 24	6,000	24 x 36	15,500
8 x 10	1,700	16 x 16	6,500	30 x 30	15,000
8 x 12	2,000	16 x 20	7,250	30 x 36	16,000
10 x 10	3,000	16 x 24	8,500		
10 x 16	3,200	16 x 30	10,000		

Size (Inch)	Weight for ASME 300# (Kg)	Size (Inch)	Weight for ASME 300# (Kg)	Size (Inch)	Weight for ASME 300# (Kg)
4 x 6	454	10 x 18	1,588	20 x 20	5,103
4 x 8	499	10 x 20	1,724	20 x 24	5,670
4 x 10	567	12 x 12	1,814	20 x 30	6,350
6 x 6	499	12 x 16	1,905	20 x 36	6,804
6 x 8	544	12 x 18	2,041	24 x 24	5,897
6 x 10	635	12 x 20	2,268	24 x 30	6,577
8 x 8	726	12 x 24	2,722	24 x 36	7,031
8 x 10	771	16 x 16	2,948	30 x 30	6,804
8 x 12	907	16 x 20	3,289	30 x 36	7,258
10 x 10	1,361	16 x 24	3,856		
10 x 16	1,452	16 x 30	4,536		

## Accessories and Options

For complete information and specifications on the following, contact your Sales Representative.

### Actuation/Instrumentation

- Higher Thrust Pneumatic Cylinders up to 1,000 square inch effective area
- Electric Actuators
- Hydraulic manual override for pneumatic piston actuators
- Dust boot for plug/actuator stem
- Fast response package for quick opening times
- Smart Systems/Online diagnostics

### Valve

- Other body materials
- Special end connections
- Special trim materials
- Custom trim characterization
- Body drain plug
- Extension bonnets

### Documentation and Test

- Nondestructive examination
- Response verification
- Certified material test reports
- Flow testing (through 8" outlet only)





## Direct Sales Office Locations

### Australia

Brisbane  
Phone: +61-7-3001-4319

Perth  
Phone: +61-8-6595-7018

Melbourne  
Phone: +61-3-8807-6002

### Brazil

Phone: +55-19-2104-6900

### China

Phone: +86-10-5738-8888

### France

Courbevoie  
Phone: +33-1-4904-9000

### India

Mumbai  
Phone: +91-22-8354790

New Delhi

Phone: +91-11-2-6164175

### Italy

Phone: +39-081-7892-111

### Japan

Tokyo  
Phone: +81-03-6871-9008

### Korea

Phone: +82-2-2274-0748

### Malaysia

Phone: +60-3-2161-03228

### Mexico

Phone: +52-55-3640-5060

### Russia

Veliky Novgorod  
Phone: +7-8162-55-7898

Moscow

Phone: +7-495-585-1276

### Saudi Arabia

Phone: +966-3-341-0278

### Singapore

Phone: +65-6861-6100

### South Africa

Phone: +27-11-452-1550

### South & Central America and the Caribbean

Phone: +55-12-2134-1201

### Spain

Phone: +34-935-877-605

### United Arab Emirates

Phone: +971-4-8991-777

### United Kingdom

Phone: +44-7919-382-156

### United States

Houston, Texas

Phone: +1-713-966-3600

Find the nearest local Channel Partner in your area:  
[valves.bakerhughes.com/contact-us](http://valves.bakerhughes.com/contact-us)

## Tech Field Support & Warranty:

Phone: +1-866-827-5378  
[valvesupport@bakerhughes.com](mailto:valvesupport@bakerhughes.com)

[valves.bakerhughes.com](http://valves.bakerhughes.com)

Copyright 2020 Baker Hughes Company. All rights reserved. Baker Hughes provides this information on an "as is" basis for general information purposes. Baker Hughes does not make any representation as to the accuracy or completeness of the information and makes no warranties of any kind, specific, implied or oral, to the fullest extent permissible by law, including those of merchantability and fitness for a particular purpose or use. Baker Hughes hereby disclaims any and all liability for any direct, indirect, consequential or special damages, claims for lost profits, or third party claims arising from the use of the information, whether a claim is asserted in contract, tort, or otherwise. Baker Hughes reserves the right to make changes in specifications and features shown herein, or discontinue the product described at any time without notice or obligation. Contact your Baker Hughes representative for the most current information. The Baker Hughes logo, Masoneilan, Lo-db and V-LOG are trademarks of Baker Hughes Company. Other company names and product names used in this document are the registered trademarks or trademarks of their respective owners.

**Baker Hughes** 