

Masoneilan™

535V Reducing and 535V-50

Differential Pressure Regulators

(Microflow Regulator)

Instruction Manual (Rev. A)

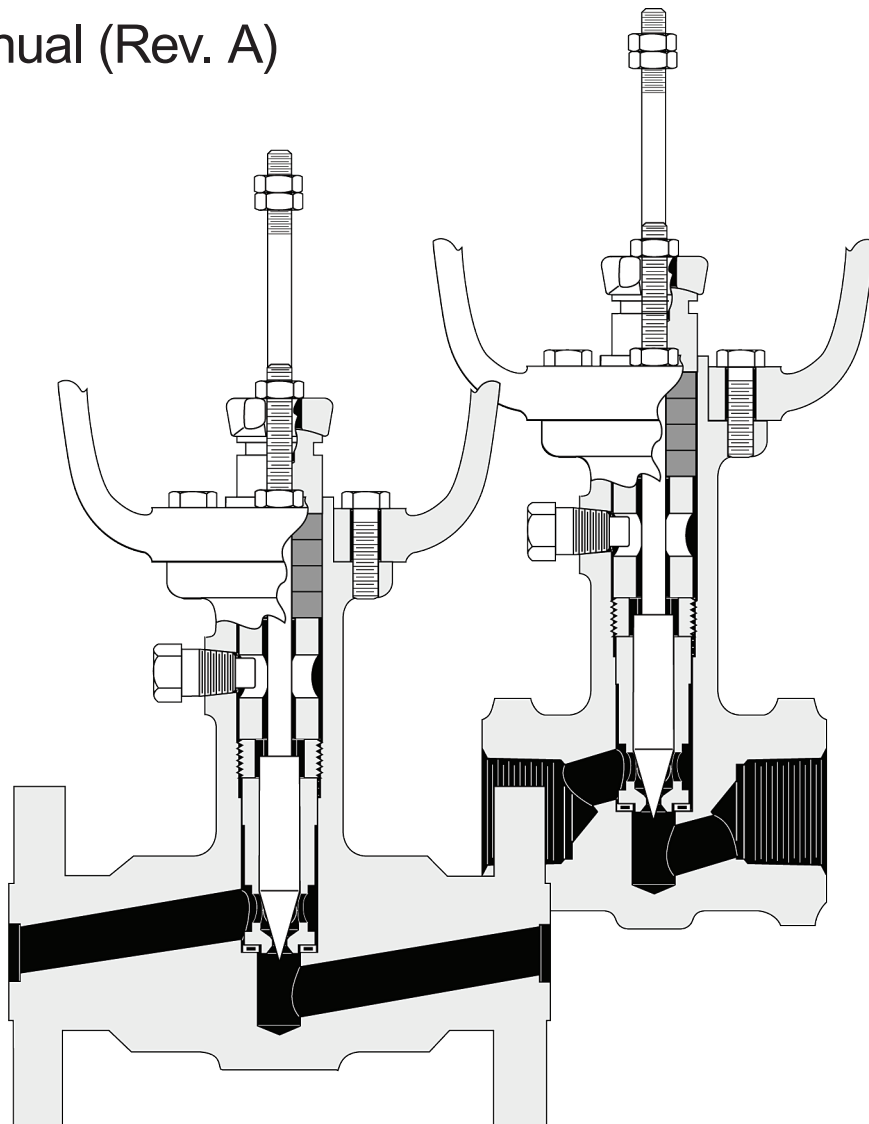

DISCLAIMER

THESE INSTRUCTIONS PROVIDE THE CUSTOMER/OPERATOR WITH IMPORTANT PROJECT-SPECIFIC REFERENCE INFORMATION IN ADDITION TO THE CUSTOMER/OPERATOR'S NORMAL OPERATION AND MAINTENANCE PROCEDURES. SINCE OPERATION AND MAINTENANCE PHILOSOPHIES VARY, BAKER HUGHES COMPANY (AND ITS SUBSIDIARIES AND AFFILIATES) DOES NOT ATTEMPT TO DICTATE SPECIFIC PROCEDURES, BUT TO PROVIDE BASIC LIMITATIONS AND REQUIREMENTS CREATED BY THE TYPE OF EQUIPMENT PROVIDED.

THESE INSTRUCTIONS ASSUME THAT OPERATORS ALREADY HAVE A GENERAL UNDERSTANDING OF THE REQUIREMENTS FOR SAFE OPERATION OF MECHANICAL AND ELECTRICAL EQUIPMENT IN POTENTIALLY HAZARDOUS ENVIRONMENTS. THEREFORE, THESE INSTRUCTIONS SHOULD BE INTERPRETED AND APPLIED IN CONJUNCTION WITH THE SAFETY RULES AND REGULATIONS APPLICABLE AT THE SITE AND THE PARTICULAR REQUIREMENTS FOR OPERATION OF OTHER EQUIPMENT AT THE SITE.

THESE INSTRUCTIONS DO NOT PURPORT TO COVER ALL DETAILS OR VARIATIONS IN EQUIPMENT NOR TO PROVIDE FOR EVERY POSSIBLE CONTINGENCY TO BE MET IN CONNECTION WITH INSTALLATION, OPERATION OR MAINTENANCE. SHOULD FURTHER INFORMATION BE DESIRED OR SHOULD PARTICULAR PROBLEMS ARISE WHICH ARE NOT COVERED SUFFICIENTLY FOR THE CUSTOMER/OPERATOR'S PURPOSES THE MATTER SHOULD BE REFERRED TO BAKER HUGHES.

THE RIGHTS, OBLIGATIONS AND LIABILITIES OF BAKER HUGHES AND THE CUSTOMER/OPERATOR ARE STRICTLY LIMITED TO THOSE EXPRESSLY PROVIDED IN THE CONTRACT RELATING TO THE SUPPLY OF THE EQUIPMENT. NO ADDITIONAL REPRESENTATIONS OR WARRANTIES BY BAKER HUGHES REGARDING THE EQUIPMENT OR ITS USE ARE GIVEN OR IMPLIED BY THE ISSUE OF THESE INSTRUCTIONS.

THESE INSTRUCTIONS ARE FURNISHED TO THE CUSTOMER/OPERATOR SOLELY TO ASSIST IN THE INSTALLATION, TESTING, OPERATION, AND/OR MAINTENANCE OF THE EQUIPMENT DESCRIBED. THIS DOCUMENT SHALL NOT BE REPRODUCED IN WHOLE OR IN PART WITHOUT THE WRITTEN APPROVAL OF BAKER HUGHES.

Safety Information

Important –

Please read before installation

These instructions contain **DANGER**, **WARNING**, and **CAUTION** labels, where necessary, to alert you to safety related or other important information. Read the instructions carefully **before** installing and maintaining your regulator. **DANGER** and **WARNING** hazards are related to personal injury. **CAUTION** hazards involve equipment or property damage. Operation of damaged equipment can, under certain operational conditions, result in degraded process system performance that can lead to injury or death. Total compliance with all **DANGER**, **WARNING**, and **CAUTION** notices is required for safe operation.



This is the safety alert symbol. It alerts you to potential personal injury hazards. Obey all safety messages that follow this symbol to avoid possible injury or death.



Indicates a potentially hazardous situation which, if not avoided, could result in death or serious injury.



Indicates a potentially hazardous situation which, if not avoided, could result in serious injury.



Indicates a potentially hazardous situation which, if not avoided, could result in minor or moderate injury.



When used without the safety alert symbol, indicates a potentially hazardous situation which, if not avoided, could result in property damage.

Note: Indicates important facts and conditions.

About this Manual

- The information in this manual is subject to change without prior notice.
- The information contained in this manual, in whole or part, shall not be transcribed or copied without Baker Hughes's written permission.
- Please report any errors or questions about the information in this manual to your local supplier.
- These two models are the "Microflow" range of the 500 Series Regulators.
- These instructions are written specifically for the Masoneilan Models 535V Reducing and Models 535V-50 Differential Pressure Regulators, and do not apply for other regulators outside of this product line.

- These two models are the "Microflow" range of the Masoneilan 500 Series regulators.
- Refer to Instructions No 31593 for connecting, adjustment and maintenance of the Masoneilan 10900 Series actuators equipping the 500 Series regulators.

Useful Life

The current estimated useful life period for the Masoneilan regulators models 535V and 535V-50 is 25+ years. To maximize the useful life of the product, it is essential to conduct annual inspections, routine maintenance and ensure proper installation to avoid any unintended stresses on the product. The specific operating conditions will also impact the useful life of the product. Consult the factory for guidance on specific applications if required prior to installation.

Spare parts

When performing maintenance, always use Masoneilan replacement parts. Parts are obtainable through your local Baker Hughes Representative or Spare Parts Department. When ordering parts, always include Masoneilan Model and serial numbers shown on serial plate.

After sales Department

Baker Hughes has a highly skilled After Sales Department available for start-up, maintenance and repair of our regulators and components parts. Contact the nearest Masoneilan Sales Office or Representative.

Training

Baker Hughes regularly holds training seminars for technicians in its factory. Please contact your local Masoneilan Representative or our Training Department.

Note: Care must be exercised when unpacking the regulator to prevent damage. Should any problems arise, contact After Sales Department. Be sure to include Masoneilan Serial and Model numbers in all correspondence.

Warranty

Items sold by Baker Hughes are warranted to be free from defects in materials and workmanship for a period of one year from the date of shipment, provided said items are used according to Baker Hughes recommended usages. Baker Hughes reserves the right to discontinue manufacture of any product or change product materials, design or specifications without notice.

Note: Prior to installation

The regulator must be installed, put into service and maintained by qualified and competent professionals who have undergone suitable training.

All surrounding pipelines must be thoroughly flushed to ensure all entrained debris has been removed from the system.

Under certain operating conditions, the use of damaged equipment could cause a degradation of the performance of the system which may lead to personal injury or death. Changes to specifications, structure, and components used may not lead to the revision of this manual unless such changes affect the function and performance of the product.

Description-Operation

535V Regulators

The 535V Direct Operated Regulators are designed to maintain a uniform reduced pressure. Microflow bodies of regulators are offered in single seat type.

Operation

The adjustable spring is set for the desired controlled pressure. This spring holds the plug open. An increase in controlled pressure above the set point causes regulators to close.

Variations in the controlled pressure thus cause the necessary regulators movement to restore the controlled pressure to set point.

535V-50 Regulators

Masonilan 535V-50 Series Differential Pressure Regulators are designed for maintaining one pressure in excess of another (reference) pressure by an adjustable amount. Microflow bodies of regulators are offered in single seat type.

Operation

The adjustable spring of actuator is set for the desired differential pressure. This spring holds the regulator open. An increase in differential above the set point causes the 535V-50 regulators to close.

Variations in the differential pressure thus cause the necessary regulator movement to restore the controlled pressure to set point.

Plug and seat ring combination (trim)

Eight plugs and five seat rings can be used in combination to obtain ten different plug and seat ring assemblies (See Figure 2).

Each plug design and the seat ring orifice diameter permit to identify parts in relation to Figure 2.

The four plugs corresponding to trim Nos 6 to 9 differ by the angle of the flat, machined on the point. The same seat ring (3e) and the same spacer (3f) are used in the four cases.

See Figure 2 to select the plug and seat ring combination to obtain the required C_v .

Installation

Before installing, blow out line thoroughly to remove all foreign matter which might foul the regulator.

Place the regulator vertically in a horizontal run of pipe so that the controlled fluid will flow through the body in the direction indicated by the arrow on the body or the words "IN & OUT" marked on the connections. On steam service, the regulator should be installed with the diaphragm chamber down so that the diaphragm will be protected by a water seal. If installed otherwise, an adequate water seal or seals must be provided.

A three valve by-pass around the regulators permits removing the regulator from the line without shutting off the flow.

See Figure 1 for typical installation diagrams.

On 535V Regulators

Pipe the controlled pressure from a convenient point in the line 6-10 feet (1,8 to 3 m) from the regulator (or in the discharge line, 6-10 feet from the pump on pump pressure applications), to the 1/2" NPT connection in the diaphragm case.

Install a gauge and a needle valve in the controlled pressure line, to protect diaphragm case against any over- pressure.

Needle valve permits shutting off the control line and also serves as an adjustable choke to prevent cycling of the regulator, which may result from the pulsation of a pump in the system.

On 535V-50 Regulators

WARNING

Pressure must be increased on both sides of the diaphragm at the same time in order to avoid diaphragm failure.

Pipe the **higher** pressure fluid from a convenient point to the 1/2" NPT connection in the upper diaphragm case (i.e., to diaphragm chamber where pressure will oppose the spring). Pipe the lower pressure fluid to the diaphragm chamber.

Install a needle valve and gauge in each of these control lines, sufficiently near each other so that both valves can be reached simultaneously.

Needle valves permit shutting off both control lines and may be used as adjustable chokes to prevent cycling of the regulator as a result of pump pulsations. By adjusting both valves simultaneously, accidental over-pressuring either side of the diaphragm can be avoided.

CAUTION

Tests have been performed at the factory to check correct operation of the regulator on its full nominal spring range. After that, the spring compression has been fully removed to avoid unnecessary stress of parts (diaphragm, spring) during storage.

THEREFORE IT IS NECESSARY TO PROCEED WITH ADJUSTMENT BEFORE SERVICING.

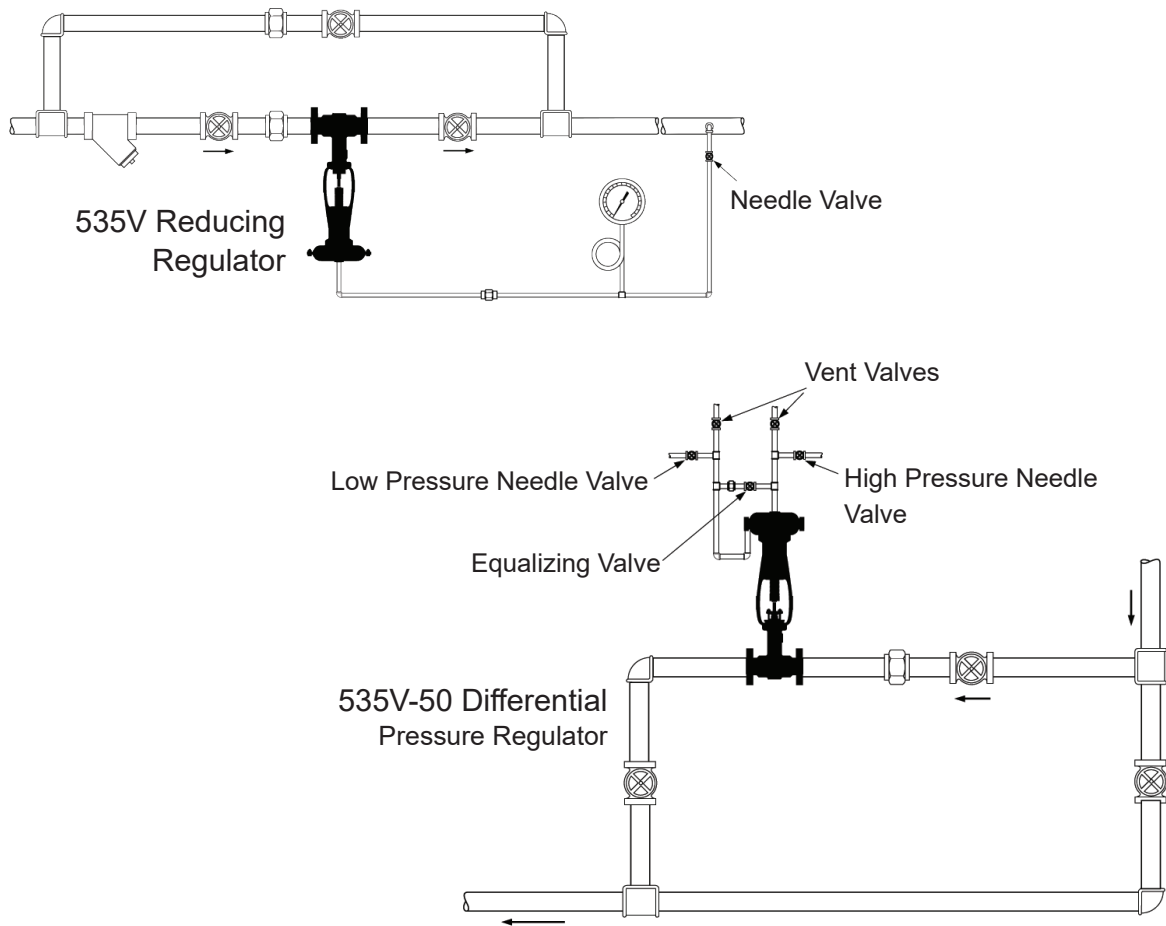

Figure 1 - Typical Installation

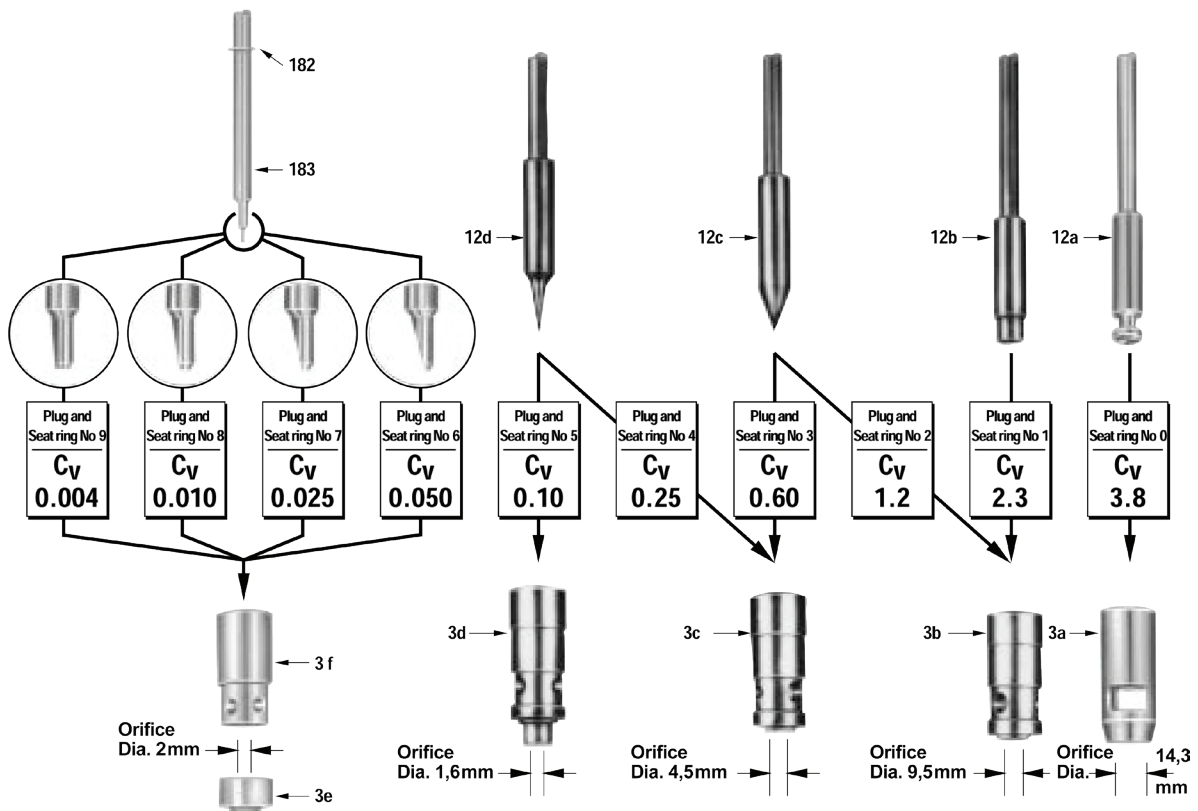

Figure 2 - Ten plug and seat ring assemblies (Trim)

Maintenance

If there is excessive leakage through the regulator when it is shut off, the cause may be:

1. Foreign matter holding valve off seat : disassemble and clean.
2. Normal wear of seating surfaces : disassemble and replace plug and/or seat ring.
3. Seat ring gasket (2) damaging (except with trim for C_v max. 3.8) : replace gasket.

CAUTION

Regulator must be isolated and pressure vented before disassembly.

Disassembly (Figure 3)

- Disconnect the control line(s) at the diaphragm case.
- Remove the two packing flange nuts (8b). Raise packing flange (10) up the plug stem and remove the two nuts (8a) as well as the two mounting screws (16).
- By means of two flat spanners, unlock the plug stem nuts (27) and unscrew them to the threaded end of the plug stem (12 or 183). Tighten nuts in this position.
- Fasten the actuator to a hoisting gear and very slowly pull out the actuator-plug S/A.
- With a flat spanner applied on the nuts (27), unscrew the plug stem from the actuator stem while pulling out vertically and slowly the actuator. Carry on until plug stem is fully unscrewed from actuator stem.

CAUTION

Carefully avoid that seating surface of the plug contacts the seat ring during the plug unscrewing.

- Separate actuator and packing flange (10) from the body S/A.
- Remove two nuts (27) and packing follower (9) from the plug stem.
- Using a packing hook, remove the largest number of packing rings (6) from packing box. Remove safety pin (11) and pull plug stem to remove packing spacer (5) and the remainder of packing rings.
- Using a 9/16" or 14 mm piece of hex stock and a wrench, unlock and pull out seat ring retainer (4).
- Pull out seat ring (3) and gasket (2) using a hook made from steel wire, diameter about 3 mm. Carefully fettle the hook end.

Note: The seat ring with $C_v < 0.10$ consists of two parts: The seat ring proper (3e) and a spacer (3f). The small size of orifice of these parts does not allow for their removal by means of a hook. Therefore, it is necessary to remove the body from the pipe, turn it over and, if needed, to hit the bottom with a wooden mallet. Should the seat ring be jammed in its housing, it is possible to move it using a screwdriver inserted through the outlet orifice.

Reassembly and Plug Stem Adjustment (Figures 3, 4, and 5)

Before reassembly, thoroughly clean the inside of the valve body and parts. Mating surfaces must be thoroughly cleaned. On reassembly, new seat ring gasket (2) and new packing (6) must be used.

- Place a new seat ring gasket (2) in the valve body (13) and install the seat ring (3) taking care to correctly center the gasket on the seat ring shoulder. Orient it in such a manner that one of its ports lines up with the body outlet orifice.

Note: For a C_v smaller than 0.10, the seat ring (3e) shall first be positioned on the new gasket (2) taking the same precautions as shown above. Next, engage spacer (3f) and orient one of its ports towards the body outlet orifice.

Regulator with C_v 3.8 does not feature any seat ring gasket (2).

- Carefully apply Never Seez grease (or equivalent) to threads and bottom of retainer (4). With a 9/16" or 14 mm piece of hex stock and a wrench, torque the retainer to 59 ft-lbs (8 daN.m) if a graphite gasket st. st. reinforced, or to 40 ft-lbs (5,5 daN.m) if a glass filled PTFE gasket. See Figure 4.



Figure 4 - Tightening the seat ring retainer (4)

Note: On regulator with C_v 3.8, torque the retainer to 15 ft-lb (2 daN.m).

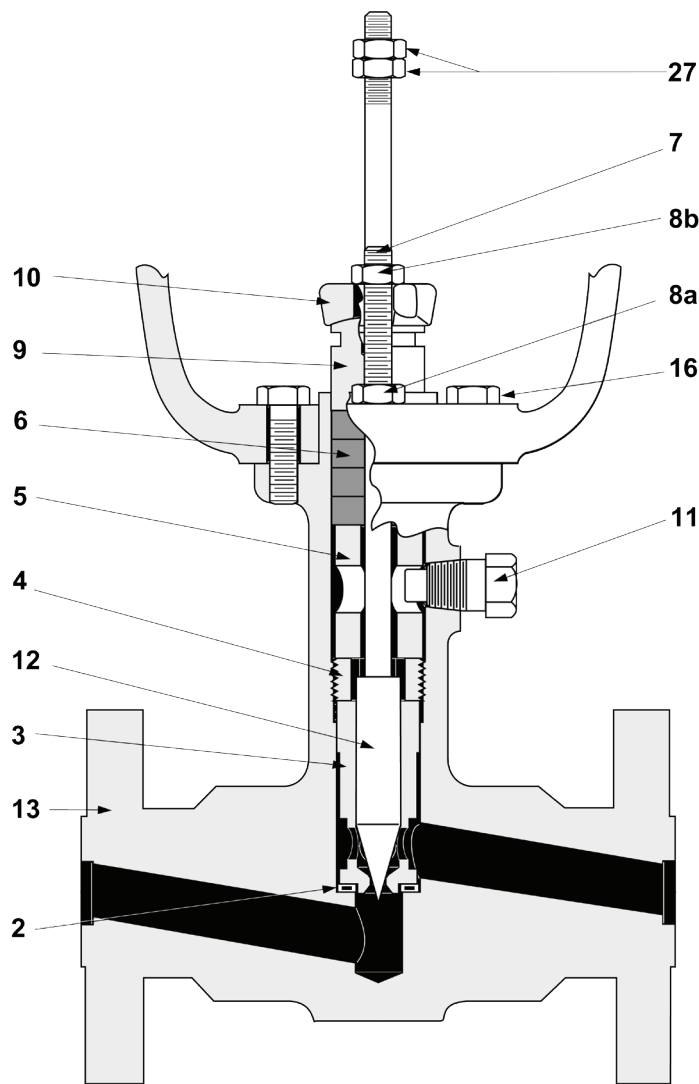

Figure 3 - Type 535V Regulator (C_v 0.60 for example)

Parts Reference

Ref.	Part Name	Ref.	Part Name	Ref.	Part Name
● 2	Seat Ring Gasket ⁽¹⁾	7	Packing Flange Stud	13	Body
3	Seat Ring	8a	Mounting Nut	16	Mounting Screw
3e	Seat Ring (Only on $C_v < 0.10^{(2)}$)	8b	Packing Flange Nut	27	Plug Stem Nut
3f	Spacer (Only on $C_v < 0.10^{(2)}$)	9	Packing Follower	● 182	Retaining Ring (Only on $C_v < 0.10^{(2)}$)
4	Seat Ring Retainer	10	Packing Flange	● 183	Plug-Stem (Only on $C_v < 0.10^{(2)}$)
5	Packing Spacer	11	Safety Pin		
● 6	Packing	12	Plug-Stem		

● = Recommended spare parts

1. Non-existent on C_v 3.8.

2. Complete sub-assembly includes: Plug-stem (183), Retaining ring (182), Seat ring (3e) and Spacer (3f). See Figure 2.

- Insert the plug-stem (12 or 183) into the seat ring (3). For a $C_v < 0.10$, ensure that there is no binding during the stroking of the plug. If binding occurs, loosen the retainer (4) and replace the seat ring (3e) in the correct position until the stem smoothly slides.
- Slide spacer (5) aligning the hole in the spacer with the safety pin (11) hole in the valve body.

Note: For a C_v smaller than 0.10, ensure that the retaining ring (182) is placed on the plug before engaging it in the spacer (3f). If the retaining ring is damaged, replace it.

- Wrap the safety pin (11) with two turns of PTFE tape (Teflon). Screw it into the bonnet five and a half to six turns from where threads engagement starts.

Note: To find start of threads engagement, proceed as follows:

- a. Screw safety pin about one turn,
- b. Pull safety pin outwards while unscrewing it.

•

- Install packing, positioning the skive cut of each packing ring 120° away from the cut of an adjacent ring. Slightly push down rings one after another using a tube 1/2" schedule 160 size. Install packing follower (9) on the plug stem.
- Hold actuator above body S/A. Before that actuator stem contacts the plug stem, screw two nuts (8a) on the two studs (7), slide packing flange (10) on the stem and the studs and screw the two nuts (27) to the threaded end of plug stem.
- While holding the plug in "Open" position, slowly pull down the actuator and screw the plug stem into the actuator stem.

Note: This operation will be facilitated turning the plug by means of a wrench applied on the nuts (27) tightened one against the other.

Carefully avoid that seating surface of the plug contacts the seat ring during the plug screwing.

Pulling down motion of the actuator and plug stem screwing must be simultaneously performed : carry on until the lower part of actuator yoke con- tacts the body flange (13).

- Screw and tighten the two screws (16). Tighten also the two nuts (8a). Finger tight the two packing flange nuts (8b).
- Unscrew the plug stem until the plug is seated.
- Screw one nut (27) against the lower part of the actuator stem while placing a 2,5 mm shim between nut and stem (see Figure 5).
- Tighten second nut (27) against the first in this position. Remove the shim and screw the plug stem into the actuator stem, until the nuts contact the actuator stem. Lock by means of a wrench applied on the nuts.
- Connect the controlled pressure line(s) to diaphragm case.
- Place back in service and tighten the nuts (8b), only as much as is necessary to stop any leakage.

Packing box

Adding Packings

To add a ring of packing, depressurize the regulator, back off packing flange nuts (8b) all the way, lift the packing flange and follower and insert one ring of packing. Tighten nuts (8b) finger tight plus one full turn.

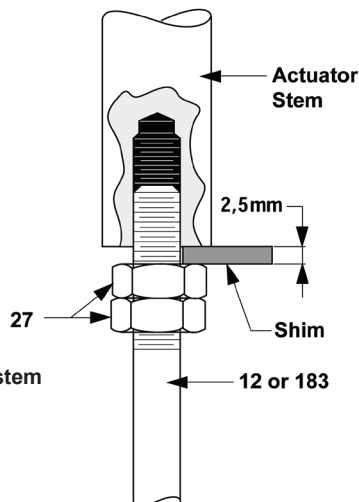

Figure 5 - Plug-stem adjustment

Packing Quick Change Method (For regulators Cv 0.6 to 3.8 only)

The fastest and simplest way to replace packing is to remove the entire actuator without disturbing actuator parts or calibration. However, this is not recommended for regulators with a small Cv ($C_v < 0.6$), due to the very fineness of their plug. In this event, disassemble the regulator to replace the packing (See under "Disassembly", page 5).

CAUTION

Regulator must be isolated and pressure vented before disassembly.

- Remove safety pin (11) from body. The safety pin engages the packing spacer (5). The function of safety pin and spacer is to prevent the plug from being pushed out if the actuator is removed while the regulator is still pressurized. The regulator internal parts cannot be removed unless the safety pin is removed first. Remove two packing flange nuts (8b) and two mounting nuts (8a). Remove also two mounting screws (16).
- Remove the actuator-plug assembly off the regulator.
- Clean the packing box and plug stem and carefully place new rings of packing around the stem. Position the skive cut of each packing ring 120° from that of the adjacent ring.
- Reassemble the actuator-plug assembly to the regulator body, taking care : (a) to align hole in spacer (5) with safety pin hole ; (b) to replace two mounting nuts (8a) before nuts (8b) ; (c) to take extra care in guiding each ring into the packing box.
- Tighten two nuts (8a) and two screws (16) on the actuator yoke.
- Wrap the safety pin (11) with two turns of PTFE tape (Teflon). Screw it into the bonnet five and a half to six turns from where threads engagement starts.

Note: To find start of threads engagement, proceed as follows:

- a. Screw safety pin about one turn,
 - b. Pull safety pin outwards while unscrewing it.
- Replace packing follower, packing flange and flange nuts (8b). Tighten nuts finger tight plus one full turn. Place back in service.

Notes:

Direct Sales Office Locations

Australia

Brisbane
Phone: +61-7-3001-4319

Perth
Phone: +61-8-6595-7018

Melbourne
Phone: +61-3-8807-6002

Brazil

Phone: +55-19-2104-6900

China

Phone: +86-10-5738-8888

France

Courbevoie
Phone: +33-1-4904-9000

India

Mumbai
Phone: +91-22-8354790

New Delhi
Phone: +91-11-2-6164175

Italy

Phone: +39-081-7892-111

Japan

Tokyo
Phone: +81-03-6871-9008

Korea

Phone: +82-2-2274-0748

Malaysia

Phone: +60-3-2161-03228

Mexico

Phone: +52-55-3640-5060

Russia

Veliky Novgorod
Phone: +7-8162-55-7898

Moscow

Phone: +7-495-585-1276

Saudi Arabia

Phone: +966-3-341-0278

Singapore

Phone: +65-6861-6100

South Africa

Phone: +27-11-452-1550

**South & Central
America and the Caribbean**

Phone: +55-12-2134-1201

Spain

Phone: +34-935-877-605

United Arab Emirates

Phone: +971-4-8991-777

United Kingdom

Phone: +44-7919-382-156

United States

Houston, Texas
Phone: +1-713-966-3600

Find the nearest local Channel Partner in your area:

valves.bakerhughes.com/contact-us

Tech Field Support & Warranty:

Phone: +1-866-827-5378

valvesupport@bakerhughes.com

valves.bakerhughes.com

Copyright 2021 Baker Hughes Company. All rights reserved. Baker Hughes provides this information on an "as is" basis for general information purposes. Baker Hughes does not make any representation as to the accuracy or completeness of the information and makes no warranties of any kind, specific, implied or oral, to the fullest extent permissible by law, including those of merchantability and fitness for a particular purpose or use. Baker Hughes hereby disclaims any and all liability for any direct, indirect, consequential or special damages, claims for lost profits, or third party claims arising from the use of the information, whether a claim is asserted in contract, tort, or otherwise. Baker Hughes reserves the right to make changes in specifications and features shown herein, or discontinue the product described at any time without notice or obligation. Contact your Baker Hughes representative for the most current information. The Baker Hughes logo, and Masoneilan are trademarks of Baker Hughes Company. Other company names and product names used in this document are the registered trademarks or trademarks of their respective owners.

Baker Hughes 